



YARD FORCE®

OUTDOOR POWER EQUIPMENT

Model YF20-RTT

YF20-RTT OHV ENGINE REAR TINE ROTARY TILLER OPERATOR'S MANUAL

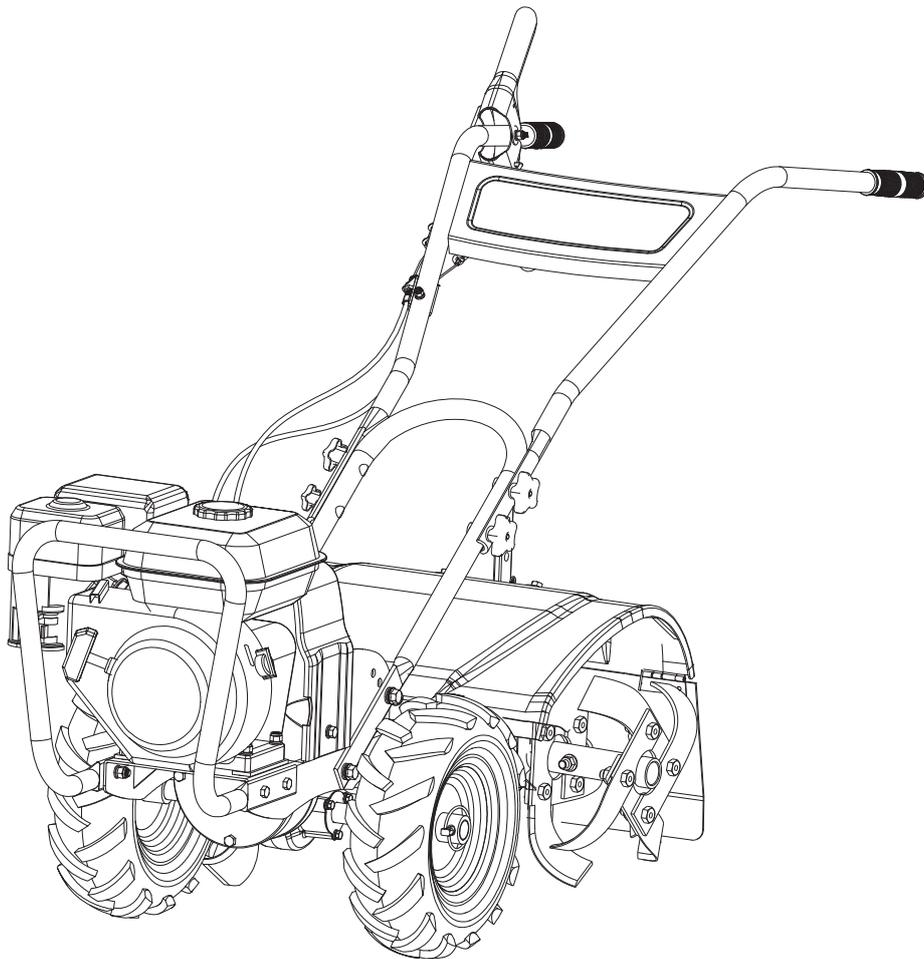

Our Customer Service staff is ready to provide assistance.

In the case of a damaged or missing part, most replacement parts ship from our facility.

For immediate help with assembly, or for additional product information, visit www.YardForceUSA.com or email support@MerotecUSA.com



SAVE THIS MANUAL FOR REFERENCE

You will need this manual for safety instructions, operating procedures, and Warranty.

The original sales receipt is required for warranty service.

YARD FORCE

YF20-RTT Original Instructions

TABLE OF CONTENTS

Safety Instructions.....	3
Parts List.....	8
Intended Use.....	9
Technical Specifications.....	10
Assembly	10
Operation	15
Maintenance and Storage.....	20
Trouble Shooting.....	25
Warranty.....	27

SAFETY INSTRUCTIONS

IMPORTANT

Please read these instructions fully before assembling and operating.

DESCRIPTION OF SYMBOLS

Symbols are used in this manual to attract your attention to possible risks. The safety symbols and the explanations which accompany them must be perfectly understood. The warnings themselves do not prevent the risks and cannot be a substitute for proper methods of avoiding accidents.

Safety Alert Symbols

The following symbols are used on the product and in this manual to alert the operator of potential safety hazards. Read them carefully, and understand their meaning.

DANGER

Indicates an imminently hazardous situation which, if not avoided, will result in death or serious injury.

WARNING !

Indicates a potentially hazardous situation which, if not avoided, could result in death or serious injury.

CAUTION

Indicates a potentially hazardous situation which, if not avoided, may result in minor/moderate injury.

NOTICE

Indicates a practice not related to personal injury which, if not avoided, may result in property damage.

The following symbols may be found on your tiller. Carefully read and understand their meaning

Safety Warning Symbols



-- Look for this symbol to point out important safety precautions. It means: Attention! Become Alert! Your Safety Is Involved.



-- Read operator's manual before operating this machine. Failure to follow directions could result in serious injury.



-- Do not use if children or bystanders are present.



-- Rotating tines can cause serious injury. Keep hands, feet, and clothing away.



-- Wear hearing protection.



-- Wear eye protection.

SAFETY INSTRUCTIONS



-- Disconnect spark plug wire when not in use or before servicing, cleaning, or performing maintenance on the unit.



-- Engines emit carbon monoxide. DO NOT run in enclosed area.



-- Engine parts, especially the muffler, become extremely hot during operation. Allow engine and muffler to cool before touching.



-- Gasoline is flammable. Allow engine to cool at least 2 minutes before refueling.

Control and Operating Symbols



-- **Oil Fill Location:** Do Not Overfill.



-- **Clutch Lever:** Depressing the upper lever engages the tines and drive wheels for the tilling operation. Depressing the lower engages the tines and drive wheels for reversing the tiller.



-- Engine speed - FAST



-- Engine speed - SLOW



-- Engine start - Choke CLOSED.



-- Fuel Cap
Fuel Shut-off - OPEN

SAFETY INSTRUCTIONS

Responsibility of Operator

1. Carefully read and follow these safety instructions. Failure to do so can result in serious injury.
2. Know your product. Read and understand this manual before use. Compare the illustrations to unit. Learn location and function of all controls. Thoroughly understanding the unit before use will result in the best performance and safety.
3. Follow all instructions when assembling the unit. If the unit was purchased in assembled condition, the operator must check the unit carefully to make sure it was assembled according the instructions in the manual before use.

SAFETY INSTRUCTIONS

4. Regularly inspect the tiller. Make sure parts are not bent, damaged, or loose.
5. Use this equipment for its intended purpose only.
6. Operate the unit only with guards, shields, and other safety items in place and working correctly.
7. Service the unit only with authorized or approved replacement parts.
8. Complete all unit maintenance and adjustments according to the instructions in this manual.

⚠ WARNING !

To prevent accidental starting when setting up, transporting, adjusting or making repairs, always disconnect spark plug wire and put wire where it cannot contact the spark plug.

Preparation Safety

⚠ WARNING !

1. Read, understand, and follow all instructions on the machine and in this manual. Be thoroughly familiar with the controls and the proper use of the tiller before starting. Know how to stop the engine quickly.
2. Familiarize yourself with all the safety and operating decals on this equipment.
3. Thoroughly inspect the area where the tiller is to be used and remove all foreign objects. Your equipment can propel small objects at high speed causing personal injury or property damage. Stay away from breakable objects, such as house windows, auto glass, greenhouses, etc.
4. Check that all nuts and bolts are tight and equipment is in good condition before each use.

Operation Safety

⚠ WARNING !

1. Never allow children or young teenagers to operate the tiller.
2. Keep area of operation clear of all bystanders, particularly small children and pets.
3. Only allow responsible individuals, who are familiar with the instructions, to operate the tiller.
4. Do not operate the tiller while under the influence of alcohol, drugs, or other medication which can cause drowsiness or affect your ability to operate this machine safely.
5. Do not use this machine if you are mentally or physically unable to operate the machine safely.
6. Always wear ANSI compliant safety goggles or safety glasses with side shields when operating tiller to protect your eyes from foreign objects, which can be thrown from the unit.
7. Wear appropriate clothing such as a long sleeved shirt or jacket. Also wear long trousers or slacks. Do NOT wear shorts. Do NOT wear loose clothing, which could get caught in this equipment.
8. Always wear work gloves and sturdy footwear such as leather work shoes or short boots. These will protect ankles and shins from small sticks, splinters, and other flying debris, and improve traction.
9. It is advisable to wear protective headgear to protect against being struck by small flying particles, or being struck by low hanging branches, twigs, or other objects, which may be unnoticed by the operator.
10. Do not put hands or feet near or under rotating parts.
11. Exercise extreme caution when operating on or crossing gravel drives, walks, or roads. Stay alert for hidden hazards or traffic.
12. Exercise caution to avoid slipping or falling. Always be sure of your footing; keep a firm hold on the handle and walk; never run. Never operate the tiller at high transport speeds on slippery surfaces.
13. Never operate the tiller without good visibility or light.

SAFETY INSTRUCTIONS

DANGER

14. Do not run the engine indoors or inside a closed area. The exhaust fumes are dangerous, containing CARBON MONOXIDE, an ODORLESS AND DEADLY GAS.
15. Never leave the tiller unattended when the engine is running. Stop the engine and make sure all moving parts have stopped. Remove the wire from the spark plug.
16. Watch for holes, ruts, bumps, or other rough ground. Tall grass can hide obstacles.
17. Always look behind and down and use caution when using reverse or pulling the tiller towards you.
18. Never attempt to start the tiller unless both wheels are in the locked position. This acts as a brake for the tiller. Always start the tiller on the level surface.

WARNING !

19. Disengage clutch lever and stop engine before leaving the tiller in operating position. Wait until the tines come to a complete stop before removing debris or making any adjustments to the tiller.

CAUTION

20. Do not attempt to till hard soil, till too deep or till at too fast a rate that can overload the tiller.
21. If the tiller should start to vibrate abnormally, stop the engine, disconnect the spark plug wire and prevent it from touching the spark plug. Check immediately for the cause. Vibration is generally a warning of trouble.

Fuel Safety

WARNING !

1. Gasoline is extremely flammable, and gasoline vapors can explode if ignited. Handle with care.
2. Use an approved container.
3. Check fuel supply before each use, allowing space for expansion as the heat of the engine and/or sun can cause fuel to expand.
4. Fill fuel tank outdoors with extreme care. Never fill fuel tank indoors.
5. Never remove gas cap or add fuel with the engine running. Allow engine to cool before refueling.
6. Do not smoke while refueling.
7. After refueling, replace fuel tank cap securely and wipe up spilled fuel.
8. Never store fuel or tiller with fuel in the tank inside a building where fumes may reach an open flame.
9. Never fill gasoline containers or the tiller fuel tank inside of a vehicle or in a truck bed. Accidental electrical static discharge can ignite fuel vapors which could result in serious injury or death.

Storage and Maintenance Safety

WARNING !

1. Always refer to the operator's manual instructions for important details if the tiller is to be stored for an extended period.
2. Never store the tiller with fuel in the fuel tank inside a building where ignition sources are present such as water heaters, space heaters, clothes dryers, etc.

SAFETY INSTRUCTIONS

3. To reduce fire hazard, keep tiller free of grass, leaves, or other debris build-up.
4. Allow the engine to cool before storing in any enclosure.
5. After striking a foreign object, stop the engine. Remove the wire from the spark plug and keep the wire away from the plug to prevent accidental starting. Thoroughly inspect the tiller for any damage. If damaged, have the equipment repaired by a trained technician before restarting and operating.
6. Stop the engine before cleaning, repairing, or inspecting the unit. Make sure all moving parts have stopped. Let the engine cool, disconnect the spark plug wire and move it away from the spark plug.
7. Never attempt to make any adjustments while the engine is running except when specifically recommended by the manufacturer.
8. Keep the tiller in safe working condition. Check all fasteners at frequent intervals for proper tightness.
9. When servicing or repairing the tiller, do not tip the machine over or up unless specifically instructed to do so in this manual. Service and repair procedures can be done with the tiller in an upright position. Some procedures will be easier if the machine is lifted on a raised platform or working surface.
10. Use only original equipment or authorized replacement parts.
11. Never tamper with safety devices. Check their proper operation regularly.
12. Do not change the engine governor setting or over-speed engine.
13. Clean and replace safety and instruction decals as necessary.
14. To guard against engine over-heating, always have engine debris filter mounted and clean.

Children Safety

WARNING !

1. Tragic accidents can occur if the operator is not alert to the presence of children. Children are often attracted to the tiller and the tilling activity.
2. Keep children out of the tilling area and under the watchful care of a responsible adult.
3. Never assume that children will remain where you last saw them.
4. Be alert and turn tiller off if children enter the area.
5. Before and while moving backwards, look behind and down for small children.
6. Never allow children to operate the tiller.
7. Use extra care when operating near blind corners, shrubs, trees, or other objects that may obstruct vision.

PARTS LIST

KNOW YOUR TILLER

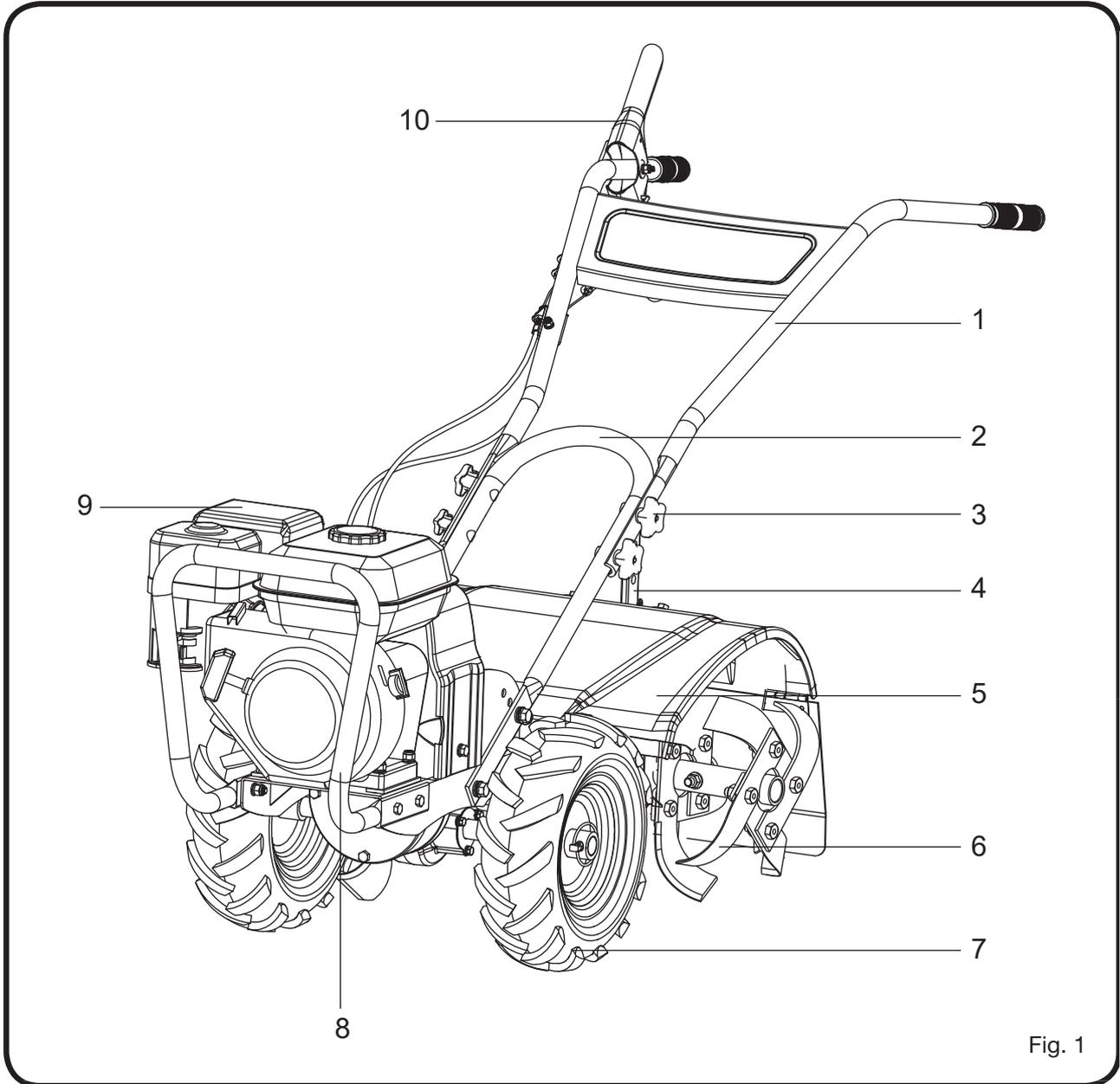

Fig. 1

1. Upper Handle
2. Lower Handle
3. Handle Knobs
4. Depth Regulator Lever
5. Tine Shield
6. Tines
7. Wheels
8. Front Guard
9. Engine
10. Forward/Reverse Lever

PARTS LIST

PARTS LIST

Carefully remove the tiller from its packaging and check that the following parts are included:

- | | |
|------------------------------|------------------------|
| A. Tiller 1pc | I. Knobs 4pcs |
| B. Upper handle Assembly 1pc | J. Bolt M8 4pcs |
| C. Front Guard 1pc | K. Bolt M8 x 20 4pcs |
| D. Depth Regulator Bar 1pc | L. Pin 1pc |
| E. Tires 2pcs | M. Wheel Lock Pin 2pcs |
| F. Manual 1pc | N. Bolt M10 x 1.5 2pcs |
| G. Bottle of Engine Oil 1pc | O. Bolt M10 x 25 2pcs |
| H. Bolt M8 x 50 4pcs | |

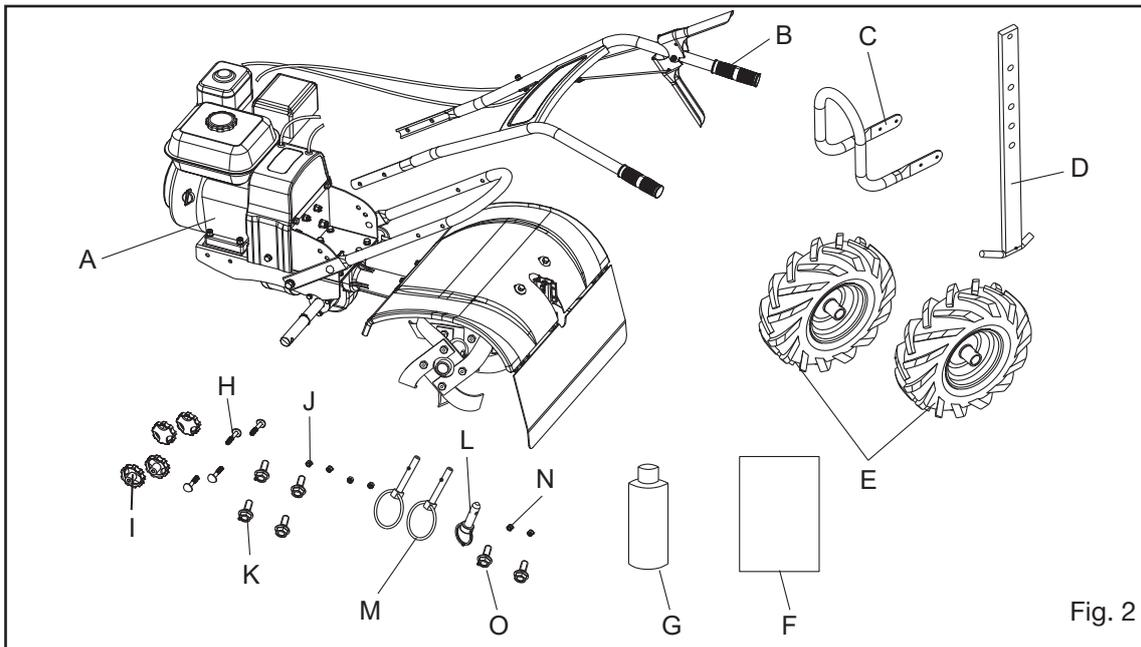

Fig. 2

⚠ WARNING !

If any parts are damaged or missing, do not operate this tiller until the missing parts are replaced. Failure to heed this warning could result in serious personal injury.

⚠ NOTICE

Always recycle the packaging in accordance with local recycling programs.

INTENDED USE

1. This gas-powered rear tine rotary tiller has been designed for tilling.
2. The machine is to be used only for its prescribed purpose. Any other use is deemed to be a case of misuse.
3. The user/operator and not the manufacturer will be liable for any damage or injuries of any kind caused as a result of this.
4. Please note that our equipment has not been designed for use in commercial, trade or industrial applications. Our warranty will be voided if the machine is used in commercial, trade or industrial businesses or for equivalent purposes.

TECHNICAL SPECIFICATIONS

TECHNICAL SPECIFICATIONS

Unit Weight	154lb(70kg)
Tilling Width	20 in (50cm)
Tilling Depth	up to 14"
Tine Diameter	15 in (38 cm)
Gasoline Capacity	3.8 US qt. (3.6 L)
Engine Oil Capacity	20 US oz (600 ml)
Spark Plug	180 lb-in (20Nm)
Spark Plug Gap	0.03 in (0.76 mm)
Engine Type	OHV 4-stroke, B&S CR950
Engine Displacement	208cc
Engine Speed (Full Throttle)	3600rpm
Engine Speed (Idle)	1800rpm
Bore Diam. x Stroke	2.76 x 2.13 in (70 x 54 mm)
Intake Valve Clearance	0.004 - 0.006 in (0.10 - 0.15 mm)
Exhaust Valve Clearance	0.006 - 0.008 in (0.15 -0.20 mm)
Tire Size	13x5.00-6 Directional Tractor Tread
Tire Pressure	25 psi min/30 psi max

ASSEMBLY

Read and follow the assembly instructions. Do not discard, any parts or materials until the unit is assembled.

References to the right or left side of the tiller are from the viewpoint of the operator's position behind the tiller.

⚠ WARNING !

- Do not operate tiller if it is damaged or not completely and correctly assembled.
- Before doing any assembly or maintenance to the unit, remove the wire from the spark plug.
- Always wear ANSI compliant safety glasses with side shields while assembling the tiller.

TO REMOVE TILLER FROM CARTON

1. Remove all parts and packaging components.
2. Use a utility knife to cut all four vertical edges and lay the side panels flat around the tiller.
3. Remove any remaining packaging.

ASSEMBLY

The tiller comes fully assembled except for a few parts. The following instructions will help you complete the tiller assembly.

INSTALLING THE WHEELS (See Fig.3)

1. Assure cupped washer is installed onto wheel axle.
2. The tiller wheels are directional. For best performance install the wheels with the tire thread facing the direction as shown.
3. Slide the wheel hub onto the wheel axle.
4. Align the wheel hub hole with the hole in the axle and insert the locking pin.
5. Rotate the locking pin ring to lock the pin in position.

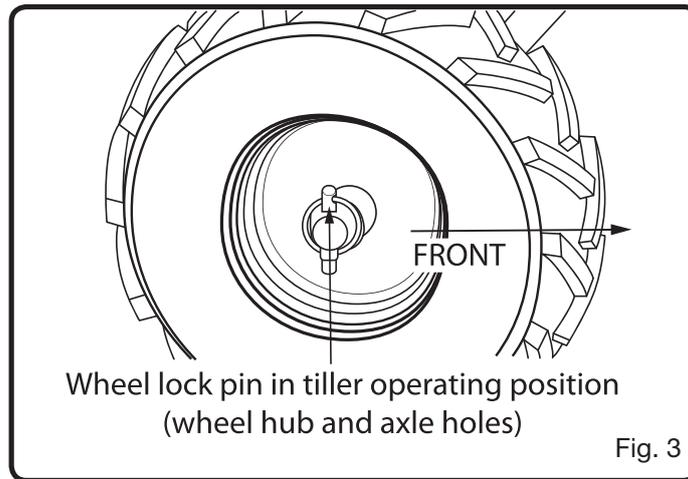

INSTALLING THE DEPTH REGULATOR (See Fig.4)

1. Insert the depth regulator into the bottom of the depth regulator bracket.
2. Insert the pin through the bracket and lever.

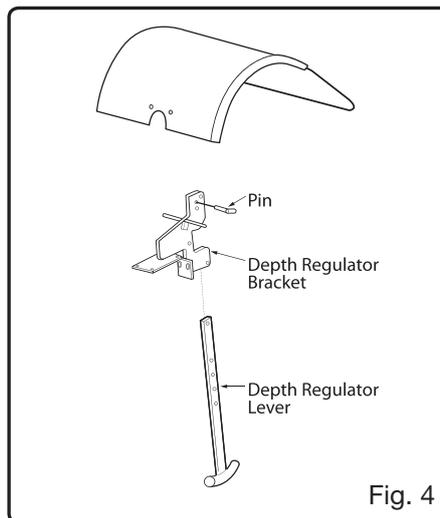

ASSEMBLY

ATTACHING LOWER HANDLE (See Fig.5)

1. Loosen the lower handle bolts, if required.
2. Align the lower handle holes to the middle height adjustment holes in the transmission cover and install the M10 X 25mm bolts, lock washers, flash washers and nuts. Tighten all four bolts at this time.

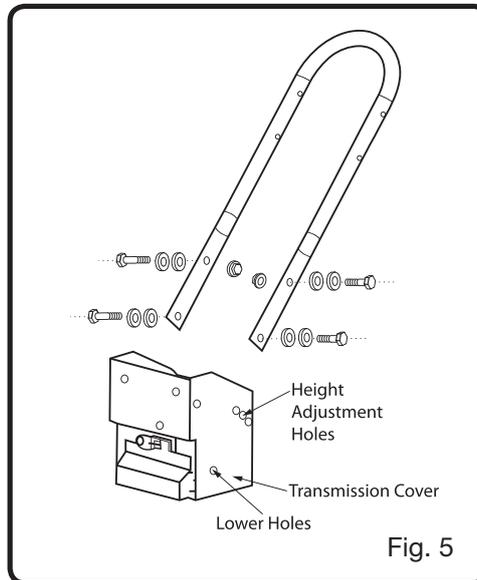

ATTACHING UPPER HANDLE (See Fig.6)

1. Slide the upper handle down over the lower handle and align the holes.
2. Insert the saddle bolts into the holes as shown and secure with the handle knobs.
3. Tighten the handle knobs securely.
4. Secure control cables to handle using cable ties.

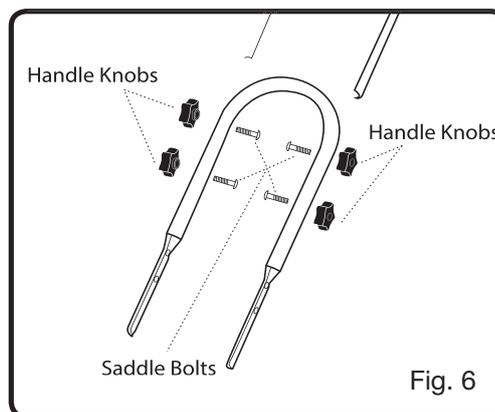

ASSEMBLY

INSTALLING FRONT GUARD (See Fig.7)

Install guard using four M8 x 20 mm hex head bolts, split lock washers, flat washers and nuts.

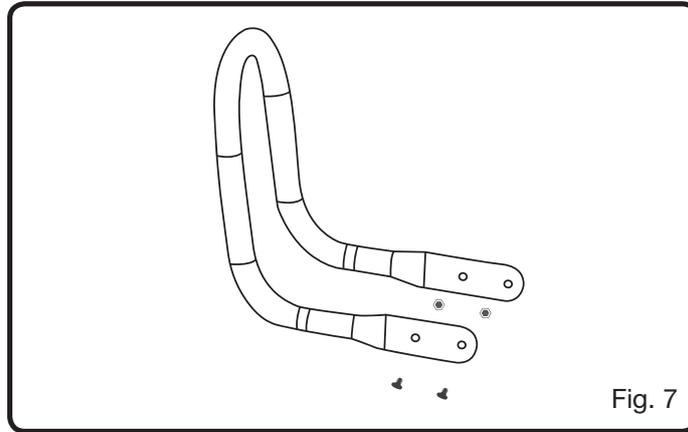

Engine Preparation

⚠ NOTICE

Engine shipped without oil. Failure to add oil will result in serious engine damage.

A bottle of engine oil is included with your tiller. Refer to the chart on the right for alternative oil types to use at different temperatures. Always use a high quality detergent oil classified "For Service, SG, SH, SJ" or higher. Do NOT use special additives.

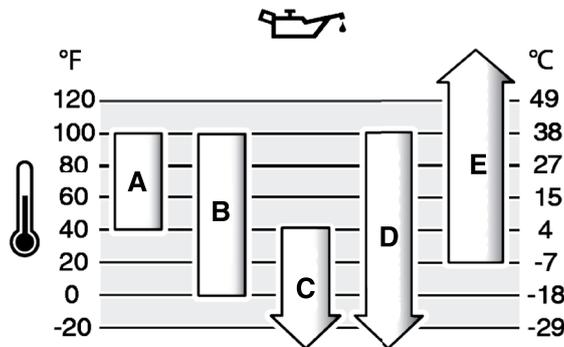

A	SAE 30 - Below 40 °F (4 °C) the use of SAE 30 will result in hard starting.
B	10W-30 - Above 80 °F (27 °C) the use of 10W-30 may cause increased oil consumption. Check oil level more frequently.
C	5W-30
D	Synthetic 5W-30
E	Vanguard™ Synthetic 15W-50

⚠ NOTICE

Always use recommended oil type. Using dirty oil or incorrect oil type such as 2-stroke engine oil will shorten engine life.

NOTE: Engine Oil Capacity is 600 ml.

CHECKING AND FILLING ENGINE OIL

ASSEMBLY

⚠ WARNING !

1. Before checking oil, make sure engine is off, and spark plug wire has been disconnected from spark plug.
2. Place the tiller on a level surface and make sure the depth regulator lever is set so the main frame of the tiller is level. (See Fig.8)
3. Remove the oil fill cap/dipstick and wipe clean with cloth. (See Fig.8)
4. Insert dipstick into fill spout but do NOT screw in. Remove dipstick and check oil level.
5. When oil level is full, the oil will be at upper limit on dipstick. If oil level is near or below the lower limit, oil must be added. (See Fig.9)
6. Add oil slowly until the oil level reaches the upper limit of the dipstick. Use a funnel or nozzle to reduce spillage.

⚠ NOTICE

Frequently check oil level while filling. DO NOT OVERFILL. DO NOT UNDER FILL. Running engine at improper oil level will seriously damage engine.

7. Replace and tighten dipstick.
8. Clean up any spilled oil.

NOTE: The transmission comes from the factory with the proper amount and type of gear oil.

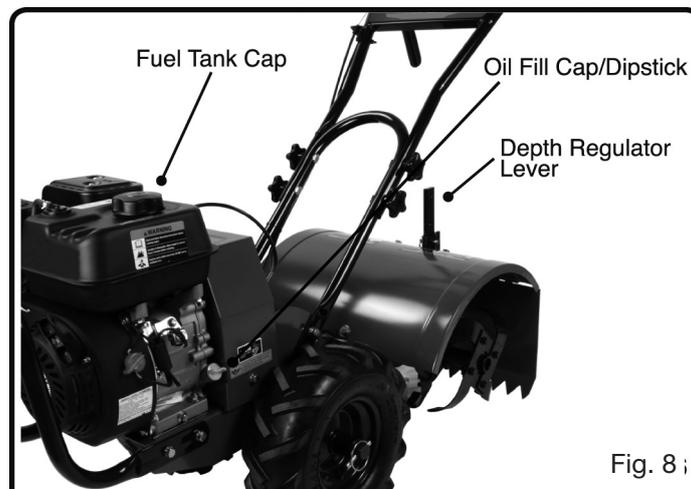

Fig. 8 ;

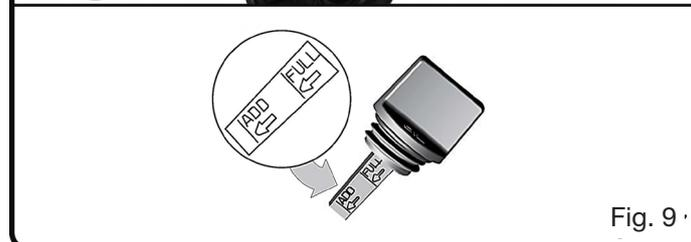

Fig. 9

OPERATION

PRE-START INSPECTION

1. Make sure all safety guards are in place and all nuts and bolts are secure. Verify the air pressure in both tires is 25- 30 psi before each use.
2. Check oil level in engine crankcase. See your engine manual for procedure and specifications.
3. Inspect air cleaner for cleanliness. See your engine manual for procedure.
4. Check the fuel supply. Use fresh unleaded gasoline with an octane rating of 87 or higher. Do not use gasoline containing more than 10% ethanol. Use of non-ethanol fuel is best. We recommend the continuous use of a fuel additive /stabilizer to counteract the effects of ethanol. These additives also prolong the shelf life of gasoline. Fill the fuel tank no closer than 1 inch from top of tank to provide space for expansion. See your engine manual for fuel recommendations.
5. Be sure spark plug wire is attached and spark plug is tightened securely.
6. Check position of wheels and wheel lockouts.
7. Check depth regulator lever position.
8. Examine underneath and around engine for signs of oil or fuel leaks.
9. Inspect fuel hoses for tightness and fuel seepage.
10. Look for signs of engine damage.
11. Remove excessive debris from muffler area and recoil starter.

IMPORTANT: Engine is shipped from factory without oil. You must add engine oil before starting engine.

CAUTION

Please do not start your tiller until you have read the manual that came with your tiller, and the sections in this manual tiller controls, adjustments and safety. If you have read these, follow the steps below to start your tiller. Always perform this pre-start checklist before starting the engine.

WARNING !

Gasoline is highly flammable and must be handled with care. Never fill the tank when the engine is hot or running. Always move outdoors to fill tank.

Wheels must always be locked in the tilling position when engine is running. Do not operate the tiller with the wheel lockouts unlocked. Always set the wheels in tilling position before starting engine.

Always put depth regulator lever in the transport position before starting engine. Tines should clear ground.

DANGER

Always keep hands and feet clear of rotating machine parts.

TO START THE ENGINE

The controls required to start and run the tiller are located on the engine and are marked with the icon for choke, slow and fast for the throttle, and on/off fuel valve. A more detailed description of engine operation and all related precautions and procedures can be found in the engine manufacturer's manual that accompanies each tiller.

COLD START

1. Turn the Engine Switch to the "on" position.
2. Move the Fuel Valve lever to the right for "on" position.
3. Move choke lever to the left for full choke "start" position.
4. Move throttle lever to "fast" position.
5. Pull starting rope out slowly one time and allow to return normally.
6. Pull starting rope out rapidly, and allow rope to return normally.

OPERATION

7. When engine starts, gradually move choke lever to the right for "run" position and increase throttle speed.

RESTARTING A WARM ENGINE

1. Restarting an engine that is already warm from previous running does not normally require use of the choke.
2. Move throttle lever to "fast" position.
3. Pull starting rope out rapidly until engine starts. Allow rope to return normally. Repeat until engine starts.
4. Adjust throttle speed to "fast" for best tiller performance.

IDLE SPEED

Use the "slow" position on the throttle lever to reduce stress on the engine when tilling is not being performed. Lowering the engine speed to "idle" will help extend the life of the engine, as well as conserve fuel and reduce the noise level of the equipment.

OPERATING SPEED

For normal tilling, set the throttle lever to "fast".

SHUTTING DOWN

To stop the engine at any time, turn engine on/off switch to the off position. To stop wheels and tines at any time, release drive safety control levers to neutral position.

TILLING

1. Adjust the depth regulator lever to desired tilling depth.

WARNING !

Raise depth regulator up one hole at a time, testing tiller operation after each raise. Raising depth regulator too high can result in loss of control of tiller!

2. Move the throttle control to fast.
3. Place the tiller in forward by pushing down on the drive safety control lever (FORWARD)--this will engage the wheels and tines.

NOTE: You can slow the tiller's forward advance at any time by putting slight downward pressure on the handlebars. You can stop the tiller by releasing the drive safety control levers to the neutral position.

NOTICE

Always press the forward or reverse drive levers down completely onto the handle bar. Failure to do so may result in excessive drive belt wear and premature drive belt failure.

WARNING !

Temperature of muffler and nearby areas may exceed 150°F. Avoid these areas. Do not move choke control to stop engine, backfire or engine damage may occur. To stop wheels and tines at any time, release drive safety control levers to neutral position. Always release drive safety control levers to neutral position AND STOP THE ENGINE before adjusting the depth of the regulator lever.

OPERATION

⚠ DANGER

Engine and surrounding parts become extremely hot during normal use and will cause serious burn injuries if touched before the engine has cooled. Allow engine to cool completely before touching these hot surfaces.

IMPORTANT: practice operating the controls and tiller with tines out of ground before beginning to till. It is important that you know how to use the tiller properly, keep control at all times, stop the tines and wheels from turning, and stop the engine if necessary. If you do not know how to do these things, read the controls, adjustments and safety sections before proceeding.

DRIVE SAFETY CONTROL LEVERS

⚠ CAUTION

Do not operate both "FORWARD" and "REVERSE" drive safety control levers at the same time. This information is provided here only to introduce the controls. Do not start the engine at this time. Please read all operating and safety instructions before starting your tiller. As a safety precaution, the drive safety control levers will not lock in the forward or reverse position.

⚠ WARNING !

Do not fix the forward or reverse drive levers in the drive position by any other means than manually using your right hand. Do not tie or otherwise secure the levers in the drive position. To stop the wheels and tines at any time release the drive safety control levers.

FORWARD LEVER (See Fig.10)

Engages wheels and tines for forwarding operation. Pushing down the drive safety control lever (FORWARD) toward the handlebar engages the wheels and tines. Releasing the lever stops the wheels and tines and brings the tiller to a complete stop.

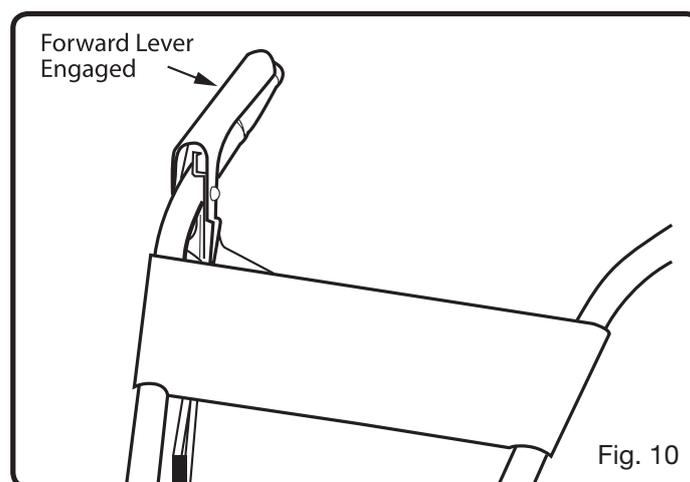

OPERATION

REVERSE LEVER (See Fig.11)

Engages wheels and tines for reverse operation. Pulling the drive safety control lever (REVERSE) toward the handlebar reverses the tiller. Releasing the lever stops the wheels and tines.

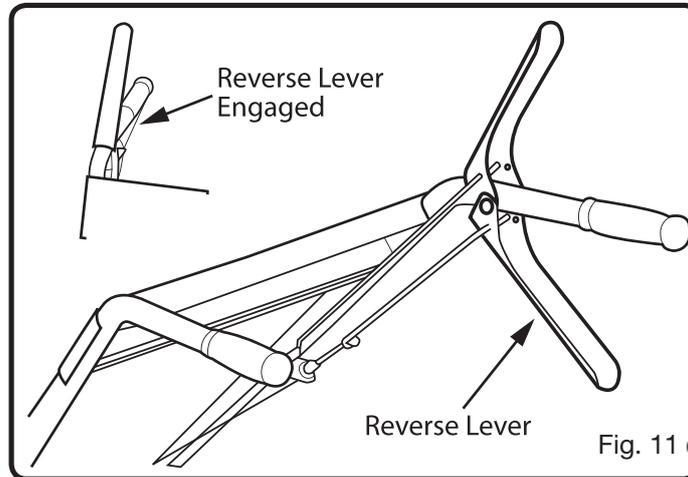

ADJUSTMENT

⚠ WARNING !

Engine should be off before adjusting any controls.
Extreme caution should be used when operating tiller in the reverse direction.

WHEEL LOCK PINS (See Fig. 3 and Fig.12)

Place wheels in tilling position.

1. Remove lock pin. Align hole in axle with hole in wheel hub.
2. Insert lock pin through holes, fold lock pin ring to secure pin to axle.
3. Firmly lock wheel and axle together before tilling.
4. Repeat for other wheel.

⚠ WARNING !

Always have both wheel lock pins in or out. Do not operate tiller with only one wheel locked.

Place wheels in free--wheel position.

1. Remove lock pin. Slide wheel inward toward machine.
2. Insert pin in axle only, fold lock pin ring to secure pin to axle.
3. Wheel should turn freely on axle.

OPERATION

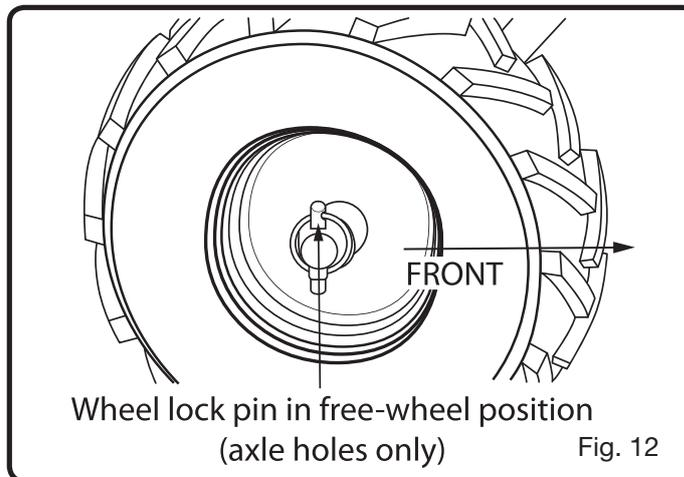

HANDLEBAR ADJUSTMENT (See Fig.5)

The ideal height of the handlebar varies with operator height and the depth of tilling. **To adjust handlebar height:**

1. Unscrew nuts and remove top bolts on each side.
2. Loosen the lower bolts. Do not remove.
3. Align handlebar to desired holes on the lower handlebar mount.
4. Install bolts and nuts. Retighten all four bolts securely.

DEPTH REGULATOR (See Fig.4)

Tilling depth is controlled by the height of the depth regulator. To adjust tilling depth:

1. Remove pin.
2. Raise the depth regulator to position tines at chosen tilling depth.
3. Align hole in depth regulator with hole in depth regulator bracket and replace pin.

Depth Regulator Down = Shallower tilling.

Place the pin in the top hole of the depth regulator for shallowest tilling.

Depth Regulator Up = Deeper tilling.

Place the pin in the bottom hole of the depth regulator for deepest tilling.

⚠ WARNING !

Do not adjust tilling depth unless drive safety control levers are released to neutral position. Always set the depth regulator in the transport position before starting engine, that is, place the detent pin in the highest hole of the depth regulator.

TILLING TIPS

The key to successful tilling is to begin with a shallow cut on the first pass, and then work an inch or two deeper on each successive pass.

1. Tilling depth will vary with ground conditions.
2. When beginning to till in unbroken ground or in extremely hard soil, set the pin in the highest hole of the depth regulator (follow instructions under Tilling section). This will allow for shallow tilling. With the

OPERATION

depth regulator in this position, make several light passes over the area to be tilled. Reset for deeper depths with successive passes.

3. If tiller jumps or skids uncontrollably, lower the depth regulator by placing the pin in a higher hole. This will allow for shallower tilling. Hold firmly to the handlebars to control sudden lurches.
4. If weeds, tall grasses, vines, or other materials clog or jam the tines, reverse the tiller to unwind vegetation.

⚠ WARNING !

Immediately release the drive control levers if the tines jam or you strike a foreign object. With drive control levers in neutral position, stop the engine. Disengage the spark plug wire. When tines have stopped, remove foreign objects and check for damage.

⚠ WARNING !

Extreme caution must be taken in selecting tilling depth. If you attempt to till too deeply for soil conditions (with the depth regulator lever in too high a position) loss of control could result.

If removing material from the tines by hand, stop engine and remove spark plug wire first.

CULTIVATING TIPS

If you plan to use your tiller for cultivating:

1. Plant rows on 20" - 22" centers for ease of turning.
2. Set the depth regulator lever with the detent pin in one of the higher holes. This will allow for shallow cultivation necessary to turn over weeds, and break up and aerate the soil.

MAINTENANCE AND STORAGE

MAINTENANCE SCHEDULE

⚠ WARNING !

Before performing any maintenance, turn engine off and remove the wire from the spark plug to prevent accidental starting and serious injury.

IMPORTANT: The warranty on this tiller does not cover items that have been subjected to operator abuse or negligence. To receive full value from the warranty, the operator must maintain the tiller as instructed in this manual, and only use genuine replacement parts. The following table lists required periodic maintenance.

MAINTENANCE AND STORAGE

PERIODIC MAINTENANCE SCHEDULE TABLE

Service Records--Fill in dates as you complete regular service	Before Each Use	After Every 10 Hours of Use	After Every 25 Hours of Use	After Every 50 Hours of Use	After Every 100 Hours of Use	Before Each Season	Before Storage	See Note Below
Check air pressure in tires	√							
Check Engine Oil Level, Fill to Proper Level	√					√		
Clean Debris From Unit	√					√	√	
Lubricate All Pivot Points		√				√	√	
Check Fasteners for Tightness		√				√		1
Check Drive Belts Replace if Necessary		√				√		
Check Tines for Wear or Damage Replace if Necessary		√				√		
Check Fuel Line Replace if Necessary			√			√		
Lubricate Wheel Axles			√			√	√	
Check Spark Plug Replace if Necessary			√			√		
Change Engine Oil				√		√	√	2,3
Clean Air Filter Replace if Necessary			√			√		4
Replace Spark Plug					√			
Clean Combustion Deposits from Cylinder, Piston, and Valves					√			
Check Transmission Oil			√			√		

⚠ CAUTION

Important notes about maintenance schedule:

1. Re-check tightness of all fasteners after first 2 hours of initial use
2. Change engine oil after first 5–8 hours of initial use
3. Change oil every 25 hours if operating under heavy load or in high temperatures
4. Clean air filter every 10 hours if operating under dusty conditions.

⚠ WARNING !

Use only GENUINE replacement parts. Other parts may damage the unit or result in injury.

SERVICING THE TILLER

The following information will help you make the necessary checks and perform the procedures required to follow the normal care recommendations made for your tiller unit. If you prefer, your local authorized dealer can make these checks and perform the required procedures for you.

⚠ WARNING !

To prevent accidental starting:

Engine must be turned off and cool. The spark plug wire must be removed and secured from spark plug before checking and adjusting engine or equipment.

MAINTENANCE AND STORAGE

CHANGING FORWARD/REVERSE BELTS (See Figure 13 and 14)

1. Turn off engine. Engine must cool completely before proceeding.
2. Remove spark plug wire and secure away from spark plug.
3. Reduce the belt tension by loosening the forward and reverse cable lower jam nut.
4. Remove the upper and lower belt guards.
5. To remove the reverse drive belt:
 - 5.1. Remove the reverse belt idler.
 - 5.2. Slide the belt free of the reverse belt guides and engine pulley.
 - 5.3. Pull belt down and away from the transmission pulley.
6. To remove the forward drive belt:
 - 6.1. Remove the two forward belt guide studs and forward belt idler assembly.
 - 6.2. Slide the belt free of the engine pulley. (Fig.14)
 - 6.3. Pull the belt down and away from the transmission pulley.
7. To install the forward drive belt:
 - 7.1. Insert the belt from underneath the unit and up around the rearward portion on the engine pulley.
 - 7.2. Place the lower loop of the belt around the rearward portion of the transmission pulley.
 - 7.3. Replace the two forward belt guide studs and forward belt idler assembly.
8. To install the reverse drive belt:
 - 8.1. Insert the belt from underneath the unit and up around the reverse belt idler.
 - 8.2. Place the lower loop of the belt around the forward portion of the transmission pulley.
 - 8.3. Replace the reverse belt idler into the reverse belt idler bracket. The belt should not go around the engine pulley. Be sure the belt is inside of the reverse belt guide studs.
9. Tighten the forward and reverse lower jam nut.
10. Check the belt tension. The belts should be loose with the drive levers disengaged.
11. Replace the upper and lower belt guards.
12. Re-attach the spark plug wire to the spark plug.
13. Follow Operating Instructions--start the engine and operate the forward drive lever to check for proper cable adjustment and belt tension.
14. Start the engine and operate the reverse drive lever to check for proper cable adjustment and belt tension

⚠ WARNING !

The tines or wheels should not rotate with the engine running, the depth regulator set at transport height (lowest height) and the drive lever not engaged.

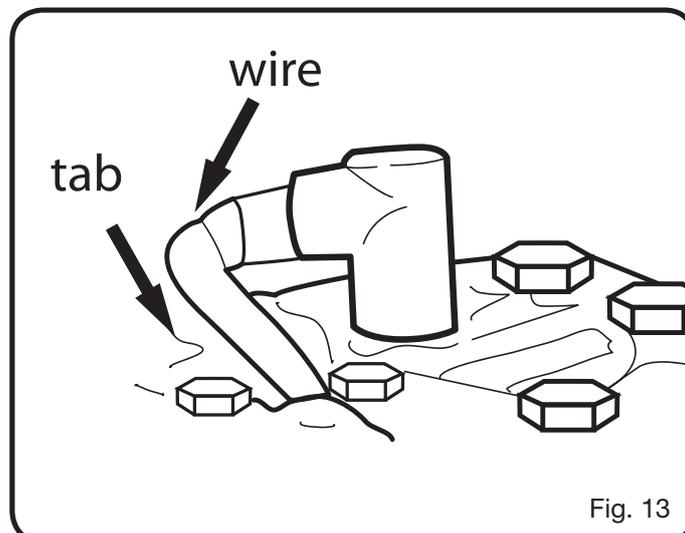

MAINTENANCE AND STORAGE

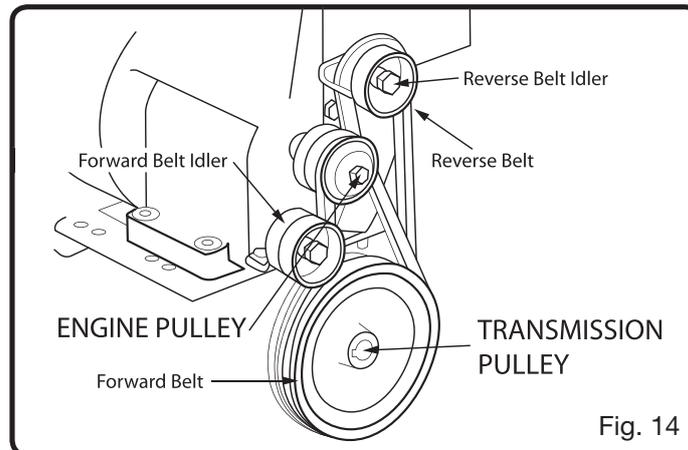

ENGINE MAINTENANCE

Refer to the engine manual included in your parts packet for information on engine maintenance. Your engine manual provides detailed information and a maintenance schedule for performing the following tasks:

1. Check oil level before each use or after every 8 hours of operation.
2. Change oil after first 5-8 hours of operation. Change oil while engine is warm. Refill with new oil of recommended grade.
3. Check spark plug yearly or every 100 hours of operation.
4. Service air cleaner.
5. Keep engine and parts clean.
6. Check engine and equipment often for loose nuts and bolts, keep these items tightened.

CHECKING OR FILLING ENGINE CRANKCASE

IMPORTANT: Engine is shipped from factory without oil. You must add engine oil before starting engine.

1. Add oil according to engine manual. Do not overfill. Use a clean, high quality detergent oil. Do not mix oil with gasoline. Oil level must be full. Check the oil level by removing oil fill plug.
2. Always check oil level before starting engine. Refer to engine manual for capacity and type of oil to use.

CHECKING TILLER TRANSMISSION OIL

IMPORTANT: Tiller transmission is shipped from factory with the proper amount of oil. When replacing oil, the tiller transmission holds 27–30 ounces. Do not overfill.

Check the oil level annually. To check the oil level:

1. Move tiller to level ground.
2. Remove oil level dipstick located between the handlebar mounts on the engine mount. If the oil level is near or below the lower limit, fill the oil to recommended level with SAE 85W–140 / 90W–140.
3. Replace oil level dipstick in the filler hole.
4. Note that the drive wheel transmission and rear tine transmission are one common reservoir. When you add to the front transmission, you must wait a short period of time for the oil to flow rearward and equalize in both front and rear. The dipstick will read correctly on level ground for both gear units.

MAINTENANCE AND STORAGE

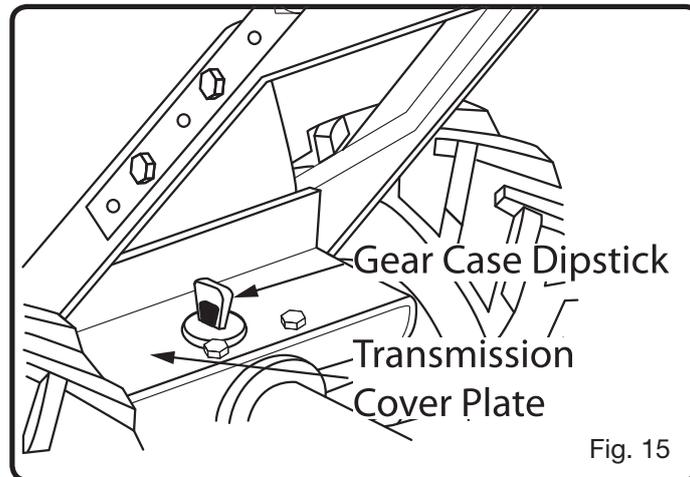

CHECKING TIRE PRESSURE

Recommended tire pressure is 25—30 PSI. If tires do not have equal pressure, tiller will pull to one side. Low tire pressure may result in damage to tire tube.

LUBRICATION

Proper lubrication of moving mechanical parts is critical for proper care and maintenance. Oil the moving parts shown at 10 hour intervals using a 30 weight oil.

CLEAN TINE AXLE SHAFT

1. Turn off engine. Engine must be cool.
2. Remove spark plug wire and secure from spark plug.
3. Tip the tiller forward. Block the tiller in position so that it rests on the engine mount and the tines are exposed.
4. Remove all vegetation, string, wire, and other material that may have accumulated on the axle between the inside set of tines and the seal cover on the transmission housing.
5. Tip the tiller back to a level position.
6. Replace spark plug wire.

STORING THE TILLER

⚠ WARNING !

Never store the tiller indoors with fuel in the fuel tank. Never store in an enclosed, poorly ventilated area where fumes could reach an open flame, a spark or a pilot light as on a furnace, water heater or clothes dryer. Allow the engine to cool before storing the unit.

⚠ WARNING !

Do not remove gasoline while inside a building, near a fire, or while you smoke. Gasoline fumes can cause an explosion or a fire.

NOTE: A yearly checkup or tune-up at an authorized service center will make sure that the tiller will provide maximum performance for the next season.

MAINTENANCE AND STORAGE

When the tiller is put in storage for thirty days or more, the following steps should be followed to make sure the tiller is in good condition the next season. To prevent fuel gum deposits and corrosion in the unit's carburetor and fuel system, it is highly recommended using a fuel additive/stabilizer formulated for ethanol fuels. Follow the stabilizer manufacturer's instructions. Run the engine for at least 5 minutes after adding stabilizer.

1. Let the engine run until it is out of gasoline. Remove the carburetor screw from bowl and drain fuel. Tilt unit slightly to remove all fuel. Replace screw.
2. Change the oil.
3. Remove the spark plug from the cylinder. Pour one ounce of oil into the cylinder. Slowly pull the recoil—start handle so that the oil will protect the cylinder. Install a new spark plug in the cylinder. Pull the starter handle slowly a few times to distribute oil. Pull recoil slowly until resistance is felt. This will close the cylinder valves.

⚠ WARNING !

Do not attach spark plug wire to spark plug when storing the unit.

4. Clean tiller. Remove all dirt, leaves, debris, grease, etc. from the tiller — including cylinder cooling fans, recoil starter cover holes, under fuel tank, and under muffler.
5. Check the tiller for worn or damaged parts. Have damaged parts replaced if necessary.
6. Tighten any loose hardware.
7. Apply lubrication as directed in Maintenance section.
8. Put the unit in a building that has good ventilation.
9. Cover the tiller with a breathing material.

TRANSPORTING THE TILLER

Empty the gas tank. Always let the engine run until it has used up the remainder of gas in the tank. Empty the engine oil from the warm engine. Remove the spark plug cover from the spark plug. Clean the cooling fins of the cylinder and the housing. Use the original packaging to ship whenever possible.

TROUBLE SHOOTING

⚠ WARNING !

Before performing any maintenance or cleaning work, switch off the engine and wait until the blade has come to a stop.

⚠ CAUTION

Improper repairs can result in the product functioning unsafely. This endangers yourself and your environment.

Faults which cannot be rectified with the aid of the following table may require service by an authorized Yard Force repair center. Please be aware that any improper repairs will also invalidate the warranty and additional costs may be incurred.

TROUBLE SHOOTING

Fault/Malfunction	Cause(s)	Solution(s)
Engine difficult to start	<ol style="list-style-type: none"> 1. Out of fuel 2. Engine Switch Off 3. Engine is not primed 4. Spark plug wire disconnected 5. Fouled spark plug 6. Dirty Carburetor 7. Clogged air filter 8. Contaminated Fuel 	<ol style="list-style-type: none"> 1. Add fresh fuel 2. Turn engine switch on 3. Move choke lever to ON position. 4. Attach spark plug wire to spark plug 5. Remove spark plug. Inspect. Replace if necessary 6. Take unit to an authorized service center for Carburetor cleaning 7. Remove and clean air filter 8. Drain fuel tank. Clean fuel tank. Fill with fresh fuel
Engine Problems: 1.Engine smokes excessively 2.Engine runs very "rough" 3.Engine runs erratically 4.Engine cannot maintain full speed	<ol style="list-style-type: none"> 1. No Engine Oil 2. Engine oil not at proper level 3. Fouled spark plug 4. Clogged air filter 5. Contaminated Fuel 6. Carburetor out of adjustment 	<ol style="list-style-type: none"> 1. Add engine oil 2. Check engine oil. Add or drain engine oil if necessary 3. Remove spark plug. Inspect. Replace if necessary 4. Remove and clean air filter 5. Drain fuel tank. Clean fuel tank. Fill with fresh fuel 6. Take unit to an authorized service center for carburetor adjustment
Excessive vibration / noise	<ol style="list-style-type: none"> 1. Loose parts 2. Engine problems (above) 3. Abnormal noise or squeal coming from belt drive 	<ol style="list-style-type: none"> 1. Tighten all fasteners 2. Refer to engine solutions (above) 3. Normally due to belt/pulley break in period. Refer to Belt Tension Adjustment section.
Tines will not rotate	<ol style="list-style-type: none"> 1. Debris interfering with tines 2. Tines loose 3. Improper drive cable adjustment 4. Damaged drive belts 	<ol style="list-style-type: none"> 1. Remove debris from around tines 2. Replace tine bolts and nuts 3. Refer to "Belt Tension Adjustment" section to decrease belt tension 4. Replace drive belts
Tines continue to rotate when drive lever is not engaged	<ol style="list-style-type: none"> 1. Improper drive cable adjustment 2. Damaged drive belts 	<ol style="list-style-type: none"> 1. Refer to "Belt Tension Adjustment" Section to decrease belt tension 2. Replace drive belts
Engine will not stop	Check switch	Replace switch
Frequent engine stalling	<ol style="list-style-type: none"> 1. Excessive tilling speed / depth 2. Engine problems (above) 	<ol style="list-style-type: none"> 1. Till at a moderate pace. Make multiple passes. 2. Refer to engine solutions (above)

WARRANTY

YARD FORCE TWO YEAR LIMITED WARRANTY

Product Warranty

Please keep your original purchase receipt in a safe place as proof of purchase. Warranty coverage for this product must be verified by the original purchase receipt. The warranty period begins on the day that the product was purchased from an authorized retailer of Yard Force products. Warranty coverage only applies to the original purchaser and is not transferable. Warranty coverage is only provided on products purchased and used in the USA and Puerto Rico from authorized Yard Force retailers. Products purchased or used outside of the USA and Puerto Rico are not covered by this warranty.

(2) Two-Year Warranty – Engine

The YF20-RTT has a 2-Year Limited Warranty from the date of purchase against manufacturer defects for residential use only. Commercial use voids the warranty. This warranty does not cover accidental damage, unreasonable use, normal wear and tear, neglect or non-compliance with the Operating, Safety and Maintenance Instructions. All service, outside of normal maintenance as described in this manual, must be done by an authorized service technician. Any unauthorized service or changes to the original configuration of this product will void the warranty. All parts and accessories used on and with this product must be manufacturer/or and authorized by Merotec Inc.

(90) Ninety-Day Warranty – Accessories

The accessories included with the YF20-RTT; like the tines, and other similar parts, are warranted against manufacturer defects for residential use only for a period of 90 days from the date of purchase. Warranty does not cover loss of use or other consequential damages arising from any of the above, nor does it cover repairs made or attempted by unauthorized persons. This warranty is void if the product is used for commercial, rental, or industrial purposes. Certain parts, attachments, and accessories are subject to normal wear and tear and are excluded from the warranty.

Service and Warranty Claims Process

Contact the Yard Force Support Center toll-free at **(866) 902-9690 Monday-Friday between 8:30 AM and 5:00 PM** Eastern Time for service and warranty support. Yard Force USA Service Support agents can help you troubleshoot problems over the phone to get you back up and running as quickly as possible.

In the situation where service or warranty inspection is needed, please follow these steps:

1. Contact Yard Force USA at **(866) 902-9690 or support@merotecusa.com Monday-Friday between 8:30 AM and 5:00 PM Eastern Time.**
2. Send in proof-of-purchase and serial number (if applicable) to confirm warranty coverage.
3. If service or a warranty evaluation is requested, Yard Force USA will provide an RGA number that should be used in all communications with Yard Force USA and if necessary a list of local authorized service centers to bring your tiller to for evaluation and repair.
4. All shipments to Yard Force USA must have an RGA number. Any shipment received that does not have an RGA number clearly marked on the outside of the box will be refused.
5. All shipments must be sent pre-paid, Yard Force USA does not pay for any shipping costs for service or warranty evaluation. Yard Force USA is not responsible for any packages that are lost by carrier. We recommend that shipments are made by a carrier that provides tracking and delivery information.

For more information or to ask questions, please call toll-free **(866) 902-9690 or support@merotecusa.com Monday-Friday between 8:30 AM and 5:00 PM Eastern Time.**

SAVE THESE INSTRUCTIONS

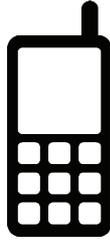

1-866-902-9690

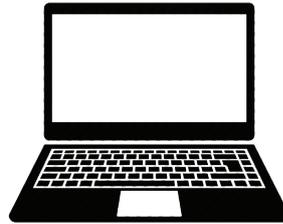

support@merotecusa.com

Need Help?

**Please do not return the product to the place of purchase yet.
We're here to help and take care of all your needs.**

Contact our Customer Care Center in Atlanta, GA for help with:

- **Product assembly or use**
- **Missing or damaged parts**
- **Troubleshooting**

**You can also visit our website to download
owner's manuals and get additional product information.
Visit www.YardForceUSA.com, or call our
toll free hotline: 1-866-902-9690 M-F 8:30am – 5:00pm ET**

Merotec Inc.
3655 Kennesaw North Industrial Parkway, Kennesaw, GA 30144
© Copyright 2022 Merotec Inc.
Made in China at a SUMEC manufacturing facility.
MADE IN CHINA

3/2021