

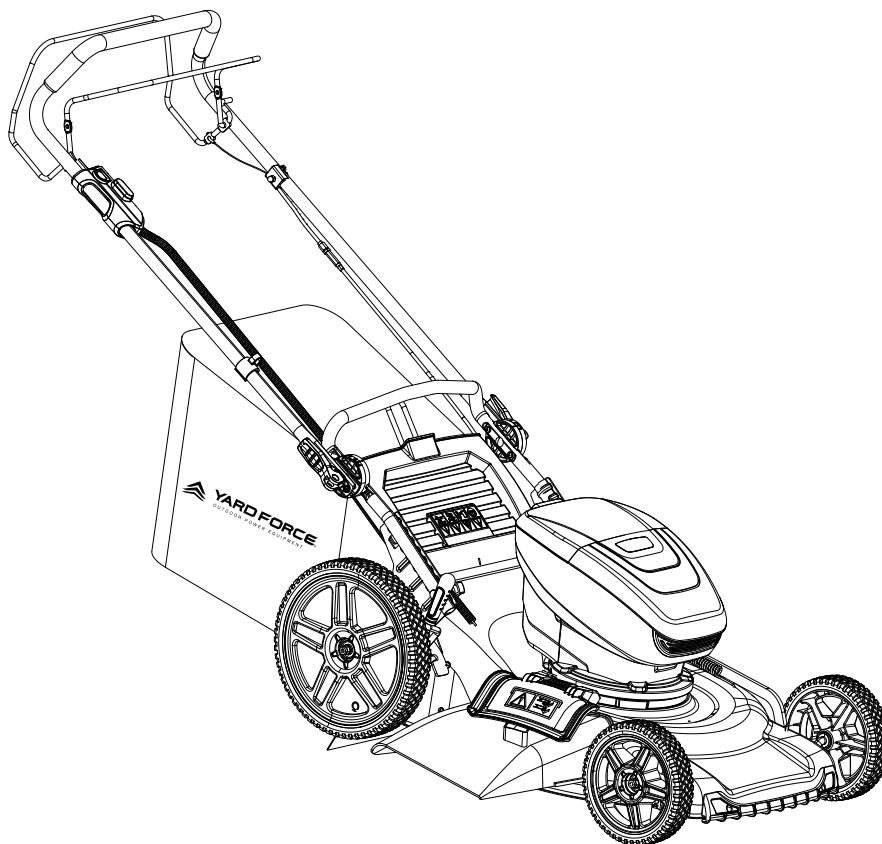

YARD FORCE[®]
OUTDOOR POWER EQUIPMENT

YF40VRX21-SP

21" CORDLESS LAWN MOWER 3-IN-1 SELF PROPELLED OPERATOR'S MANUAL



*Our Customer Service staff is ready to provide assistance.
In the case of a damaged or missing part, most replacement parts ship directly from Merotec USA in Atlanta or from one of our service partners in the US.
For immediate help with assembly, or for additional product information, email support@MerotecUSA.com or call 866-902-9690 M-F 8:30am – 5:00pm ET. More information can be found on www.YardForceUSA.com.*

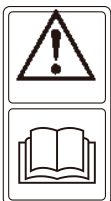

SAVE THIS MANUAL FOR REFERENCE

*You will need this manual for safety instructions, operating procedures, and Warranty.
The original sales receipt is required for warranty service.*

TABLE OF CONTENTS

| | |
|------------------------------------|----|
| Description of Product Parts | 7 |
| Intended use..... | 7 |
| Technical Specifications..... | 7 |
| Safety Information..... | 8 |
| Assembly | 13 |
| Adjustment | 14 |
| Operation..... | 14 |
| Maintenance and Storage | 16 |
| Troubleshooting | 18 |
| Warranty | 19 |

FIGURES

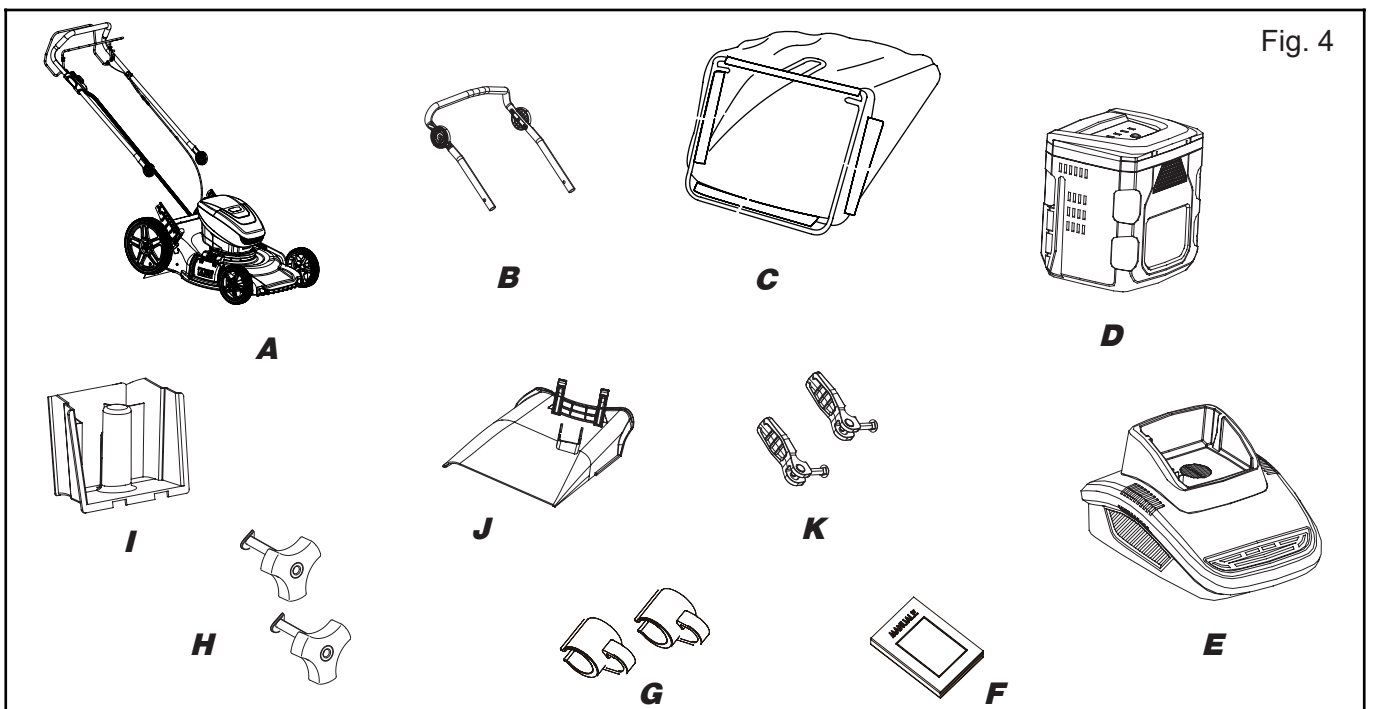
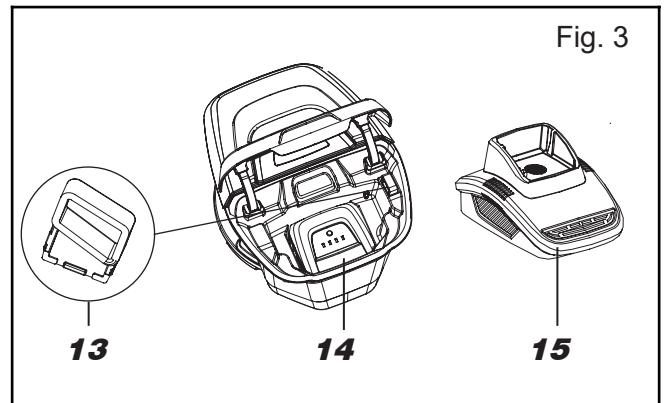
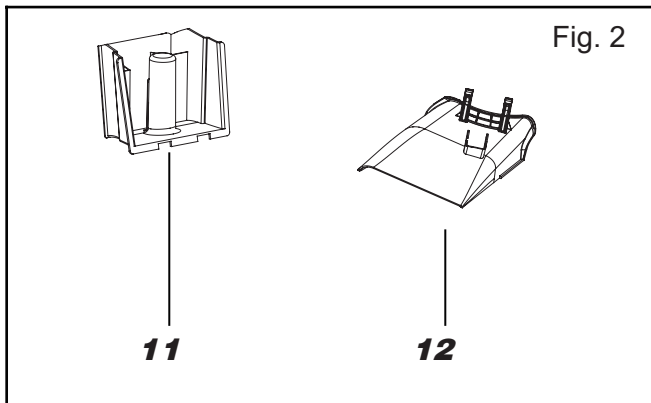
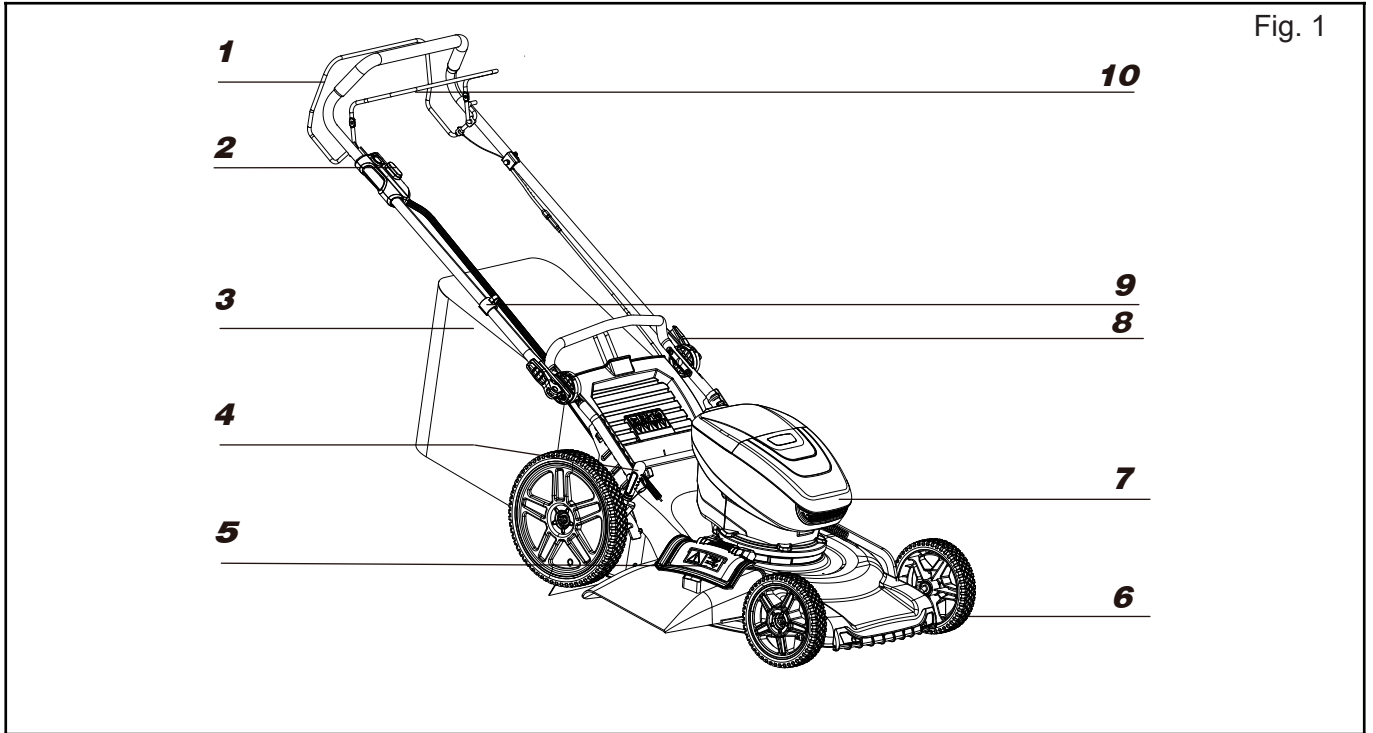

FIGURES

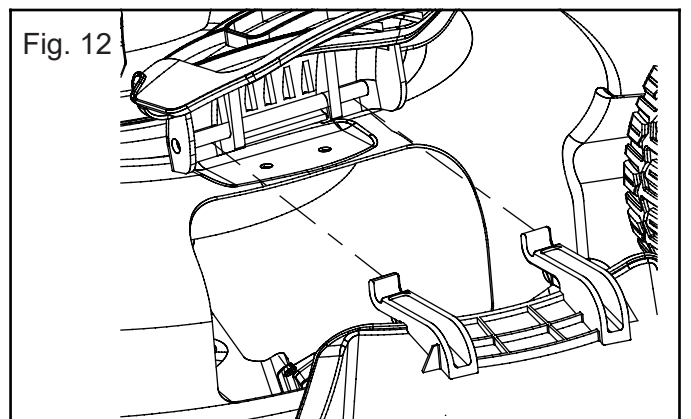
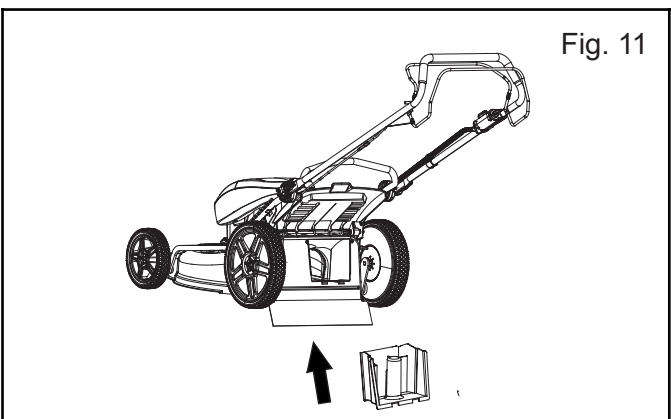
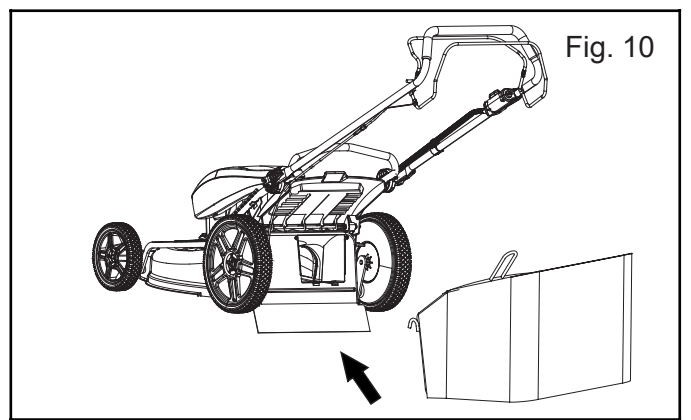
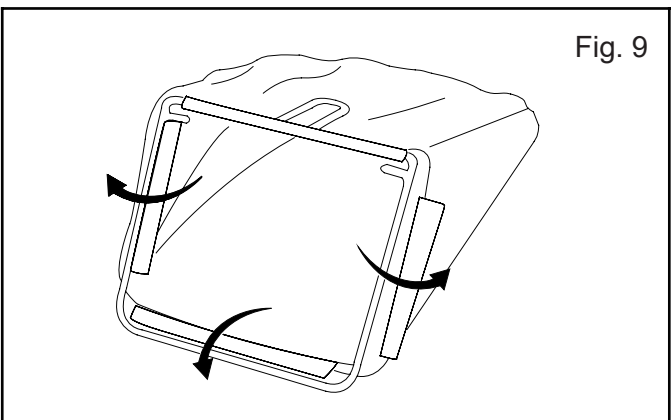
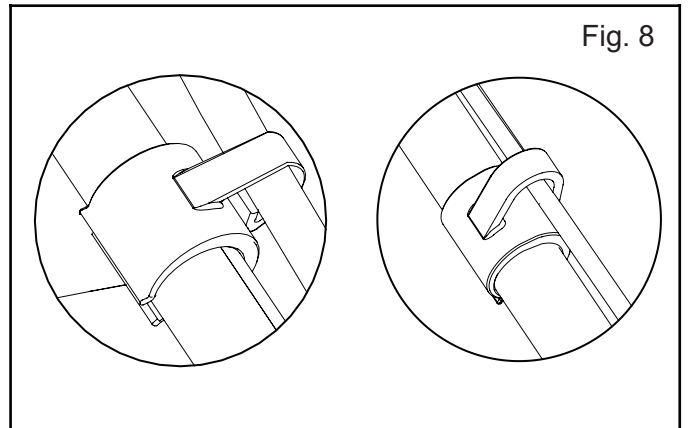
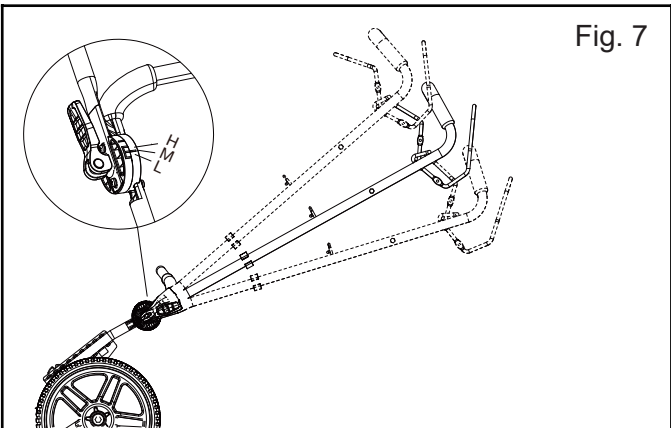
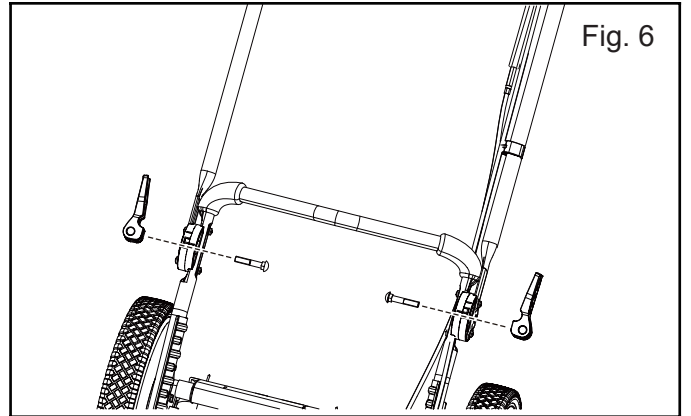
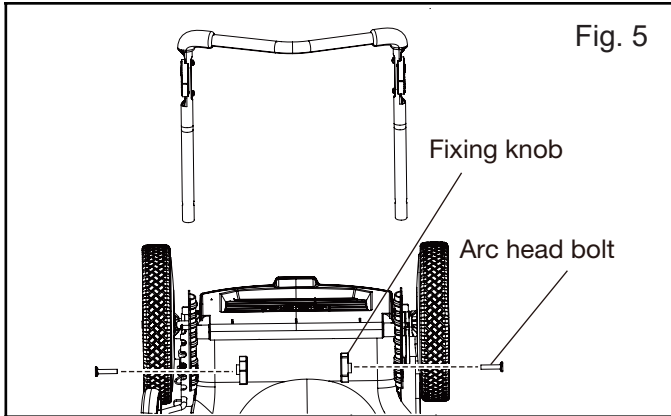

FIGURES

Fig. 13

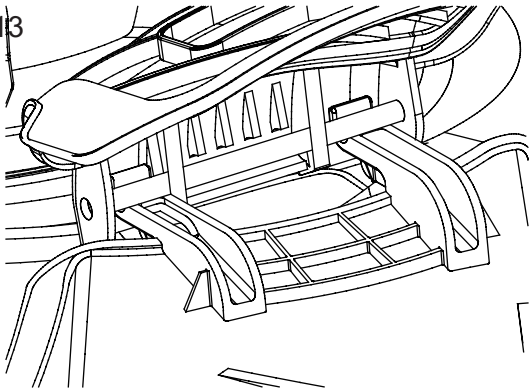

Fig. 14

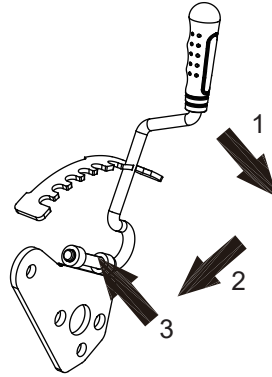

Fig. 15

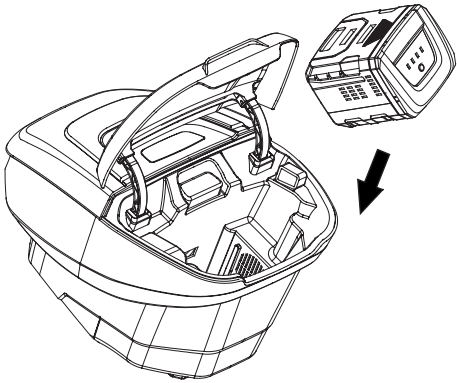

Fig. 16

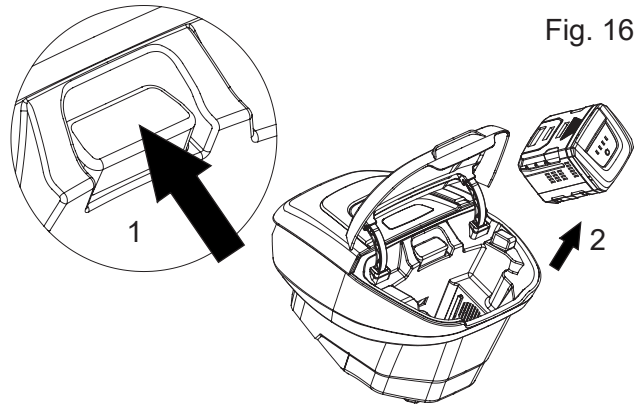

Fig. 17

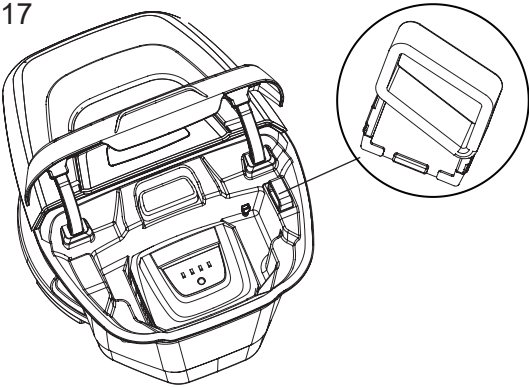

Fig. 18

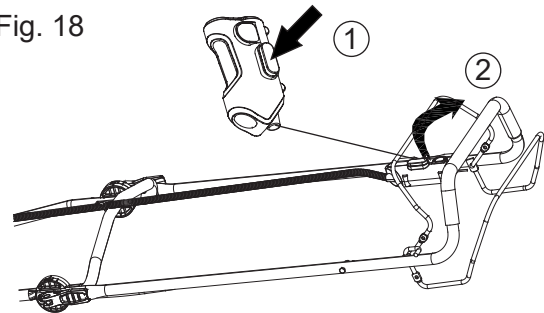

Fig. 19

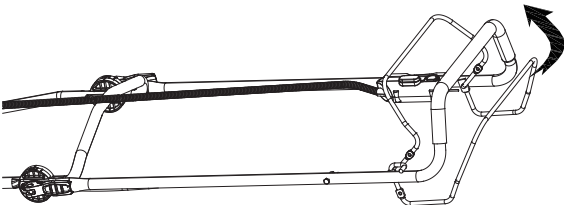
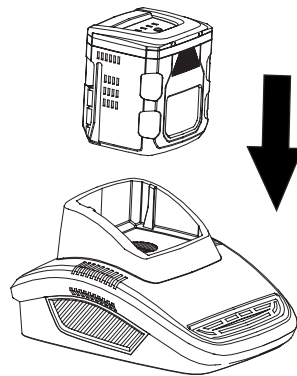
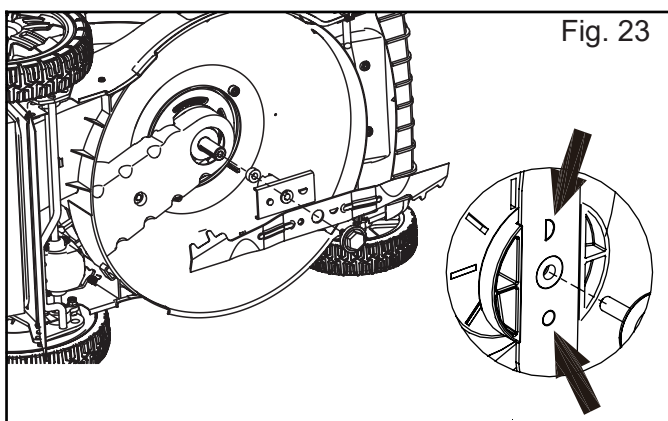
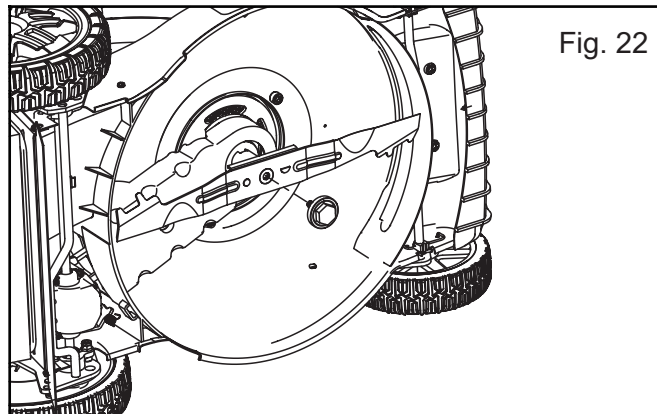
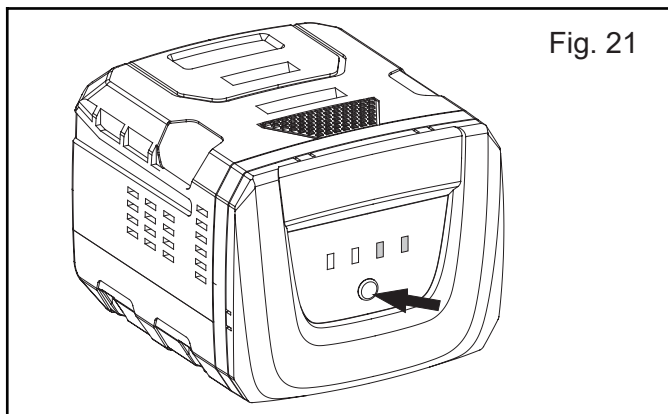

Fig. 20



FIGURES



WARNING

1. For safe operation, read and understand the instruction manual.
2. To reduce the risk of electric shock, do not expose to water or operate on wet ground.
3. Replace damaged parts immediately.
4. Disconnect and remove battery prior to servicing.
5. Remove the battery pack before servicing or removing blade.
6. Do not reach under blade guard. Go across slopes, not up and down. Do not operate within 100 ft. of people or animals.
7. Do not mow when children or others are around. Keep safety devices (guards, shields, switches etc. in place and working.
8. Look down and behind before and while moving backwards.
9. Remove objects that could be thrown by the blade.
10. To reduce the risk of eye injury, wear safety glasses.
11. Meet CPSC blade safety requirements.
12. Use only YF40vRX Li-ion battery and charger models YF40vRX4.0-BAT, YF40vRX5.0-BAT and YF40vRX3A-CHG.

DESCRIPTION OF PRODUCT PARTS

DESCRIPTION OF PRODUCT PARTS

Parts list (See Fig. 1, Fig. 2 & Fig. 3)

1. Self-propelled control bar
2. Safety lock button
3. Grass bag
4. Height adjustment knob
5. Side discharge door
6. Wheel
7. Power head
8. Handle quick-release knob
9. Cable clip
10. Operator presence control bar
11. Mulching plug
12. Side discharge chute
13. Safety key
14. Battery pack
15. Battery charger

NOTICE!

1. Remove everything from carton except the cordless Lawn Mower.
2. Open carton completely by cutting each corner from top to bottom.
3. Push the mower out from the carton.

Delivery list (See Fig.4)

- A. Main machine x 1
- B. Lower handle bar x 1
- C. Grass bag x 1
- D. Battery pack x 2
- E. Charger x 1
- F. Manual x 1
- G. Cable clip x 2
- H. Lower handle knob x 2
- I. Mulching plug
- J. Side discharge chute x 1
- K. Handle quick-release knob x 2

Carefully remove the machine and parts from its packaging. Identify all the parts packaged in the carton against the parts list. Please contact our customer service center (Monday - Friday 8:30AM - 5:00PM ET) at **(866) 902-9690** if anything is missing.



WARNING! If any parts are damaged or missing, do not operate this tool until the missing parts are replaced. Failure to heed this warning could result in serious personal injury.

NOTE! Always recycle the packaging in accordance with local recycling schemes.

TECHNICAL SPECIFICATIONS

| | |
|--------------------|---|
| Item No. | YF40VRX21-SP |
| Voltage/Capacity | 40 V d.c. / 5.0 Ah Li-ion |
| Deck Size | 21 " |
| Cutting Size | 20 " |
| Cutting Height | 7 positions: 1.25 "- 3.75" |
| Self-Propelled | Yes |
| Grass Bag Capacity | 2.0 Bushels/ 65L |
| No-load Speed | 2750 RPM |
| Booster Function | Yes (3000 RPM) |
| Wheel Size | 8 " Front/ 12 " Rear |
| Charger | Input: 100~120 V, 50/60 Hz, Output: 40 V d.c., 3.0 A |
| Charging Time | 100 Minutes |
| Battery Pack Type | YF40VRX5.0-BAT |
| Charger Type | YF40VRX3A-CHG |

INTENDED USE

This cordless lawn mower has been designed for cutting lawn areas in private house and hobby gardens.

The machine is to be used only for its prescribed purpose, any other use is deemed to be a case of misuse. The user/operator and not the manufacturer will be liable for any damage or injuries of any kind caused as a result of this.

Please note that our equipment has not been designed for use in commercial, trade or industrial applications. Our warranty will be voided if the machine is used in commercial, trade or industrial businesses or for equivalent purposes.

SAFETY SYMBOLS

SAFETY SYMBOLS

The purpose of safety symbols is to attract your attention to possible dangers. The safety symbols and the explanations with them deserve your careful attention and understanding. The symbol warnings do not, by themselves, eliminate any danger. The instructions and warnings they give are no substitutes for proper accident prevention measures.

WARNING: Be sure to read and understand all safety instructions in this Operator's Manual, including all safety alert symbols such as "DANGER," "WARNING," and "CAUTION" before using this tool. Failure to follow all instructions listed below may result in electric shock, fire, and/or serious personal injury.

SAFETY INSTRUCTIONS

This page depicts and describes safety symbols that may appear on this product. Read, understand, and follow all instructions on the machine before attempting to assemble and operate.



To reduce the risk of injury, user must read instruction manual carefully.

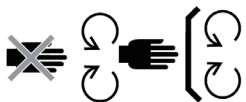

Do not open or remove safety shields while engine is running.



Keep bystanders away.



Look behind while backing.



Steep slope hazard.



Severing of toes or fingers rotary mower blade.



Thrown or flying objects whole body exposure.

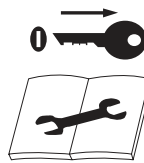

Remove disabling device before maintenance.



requirement of wearing ear protection, eye protection and gloves when using the product.



Do not expose and operate the tool in rain.



Wait until all machine components have completely stopped before touching them. The blades continue to rotate after the machine is switched off, a rotating blade can cause injury.

SAFETY SYMBOLS

Warning symbols on the battery pack



Do not throw into water



Do not litter to fire.



Do not subject the battery to strong sunlight over long periods and do not leave it on a heater (max. 113 °F).



Batteries contain Li-ion. Waste batteries should be sorted for eco-friendly. Do not dispose of waste batteries as unsorted municipal waste.



Do not expose and operate the tool in rain.



Wait until all machine components have completely stopped before touching them. The blades continue to rotate after the machine is switched off, a rotating blade can cause injury.

Warning symbols on the charger



The charger is for indoor use only.

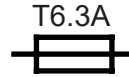

Protective 6.3 A limited.



Do not expose and operate the tool in rain.

SAFETY INSTRUCTIONS

SAFETY RULES FOR LAWN MOWER IMPORTANT SAFETY INSTRUCTIONS

READ ALL INSTRUCTIONS BEFORE USING MOWER



WARNING: When using lawn mowers,

basic safety precautions should always be followed to reduce the risk of fire, electric shock, and personal injury, including the following:

1. Avoid Dangerous Environment - Don't use lawn mowers in damp or wet locations.
2. Don't Use In Rain.
3. Keep Children Away - All visitors should be kept a safe distance from work area.
4. Dress Properly - Do not wear loose clothing or jewelry. They can be caught in moving parts. Use of rubber gloves and footwear is recommended when working outdoors.
5. Use Safety Glasses - Always use face or dust mask if operation is dusty.
6. Use Right Appliance - Do not use lawn mower for any job except that for which it is intended.
7. Don't Force Lawn Mower - It will do the job better and safer at the rate for which it was designed.
8. Don't Overreach - Keep proper footing and balance at all times.
9. Stay Alert - Watch what you are doing. Use common sense. Do not operate lawn mower when you are tired.
10. Disconnect battery pack when not in use, before cleaning or servicing, when changing accessories such as blades, and the like.
11. Store Idle Lawn Mower Indoors - When not in use, lawn mower should be stored in an indoor dry and locked-up place - out of reach of children.
12. Maintain Lawn Mower With Care - Keep cutting edges sharp and clean for best and safest performance.
13. Follow instructions for lubricating and changing accessories.
14. Inspect lawn mower cord periodically and if damaged, have it repaired by an authorized service facility. Inspect extension cords periodically and replace if damaged. Keep handles dry, clean, and free from oil and grease.
15. Keep guards in place and in working order.
16. Keep blades sharp.
17. Keep hands and feet away from cutting area.

18. Objects struck by the lawn mower blade can cause severe injuries to persons. The lawn should always be carefully examined and cleared of all objects prior to each mowing.
19. If lawn mower strikes a foreign object, follow these steps:
 - 1) Stop lawn mower. Release the control bars.
 - 2) Remove the battery pack.
 - 3) Inspect for damage.
 - 4) Repair any damage before restarting and operating the lawn mower.
20. Use identical replacement blades only.
21. Use only genuine spare parts. Only these spare parts are designed and suitable for the product. The use of other spare parts not only voids the warranty, but also endanger yourself and your environment.



WARNING: Battery posts, terminals

and related accessories contain lead and lead compounds, chemicals known to the State of California to cause cancer and birth defects or other reproductive harm. Wash hands after handling. For more information, go to www.P65Warnings.ca.gov.

SAVE THESE INSTRUCTIONS

Training

1. Read the instructions carefully. Make sure you understand the instructions and are familiar with the controls and the correct use of the product.
2. Never allow children or people unfamiliar with these instructions to use the product. Local regulations can restrict the age of the operator.
3. Never operate the product while people, especially children, or pets are nearby.
4. Keep in mind that the operator or user is responsible for accidents or hazards occurring to other people or their property.

Preparation

1. While operating the product always wear substantial footwear and long trousers. Do not operate the product when barefoot or wearing open sandals. Avoid wearing clothing that is loose fitting or that has hanging cords or ties.
2. Thoroughly inspect the area where the product is to be used and remove all objects which can be thrown by the product.

SAFETY INSTRUCTIONS

3. Before using, always visually inspect to see that the blade, blade bolt and the blade assembly are not worn or damaged. Replace worn or damaged components in sets to preserve balance. Replace damaged or unreadable labels.

General Operation

1. Use the tool only with specifically designated battery packs. Use of any other battery packs may create a risk of injury and fire.
2. Operate the product only in daylight or in good artificial light.
3. Do not expose tool and charger to rain or wet conditions. Water entering a tool or charger will increase the risk of electric shock.
4. Avoid operating the product in wet grass.
5. Always be sure of your footing on slopes.
6. Walk, never run.
7. For wheeled rotary mowers, Mow across the face of slopes, never up and down.
8. Exercise extreme caution when changing direction on slopes.
9. Do not mow excessively steep slopes.
10. Use extreme caution when reversing or pulling the product towards you.
11. Stop the blade(s) if the appliance has to be tilted for transportation when crossing surfaces other than grass, and when transporting the product to and from the area to be mowed.
12. Never operate the appliance with defective guards or shields, or without safety devices, for example deflectors and/or grass catchers, in place.
13. Switch on the motor carefully according to instructions and with feet well away from the blade(s).
14. Do not tilt the product when switching on the motor, except if the product has to be tilted for starting. In this case, do not tilt it more than absolutely necessary and lift only the part, which is away from the operator. Always ensure that both hands are in the operating position before returning the appliance to the ground.
15. Do not start the machine when standing in front of the discharge opening.
16. Do not put hands or feet near or under rotating parts. Keep clear of the discharge opening at all times.
17. Do not transport the product while the cutting blade is running.
18. Switch off and remove the key/battery pack

from the machine. Make sure that all moving parts have come to a complete stop.

- whenever you leave the product,
 - before clearing blockages or unclogging chute,
 - before checking, cleaning or working on the product,
 - after striking a foreign object. Inspect the product for damage and make repairs before restarting and operating the product;
19. If the product starts to vibrate abnormally (check immediately)
 - inspect for damage,
 - replace or repair any damaged parts,
 - check for and tighten any loose parts.
 20. Use only with the battery packs and chargers listed below:

| Battery pack | Charger |
|----------------|---------------|
| YF40VRX4.0-BAT | YF40VRX3A-CHG |
| YF40VRX5.0-BAT | YF40VRX3A-CHG |

SPECIAL OPERATION SAFETY FOR THE CHARGER

1. Recharge only with the charger specified by the manufacturer. Do not use the original charger on other li-ion batteries or on any other type of battery—fire or explosion may occur.
2. Check the battery charger, cable and plug each time before using. Do not use the battery charger when defects are detected. Do not open the battery charger yourself and have it repaired only by qualified personnel using original spare parts.
3. The charger is designed to use standard household 100~240 V, 50/60 Hz power source. The charger's plug must match the outlet. Never modify the plug in any way. Unmodified plugs and matching outlets will reduce risk of electric shock.
4. Do not abuse the cord of charger. Never use the cord for carrying, pulling or unplugging the charger. Keep cord away from heat, oil, sharp edges or moving parts. Damaged or entangled cords increase the risk of electric shock.
5. Make sure the charger cord is located so that it will not be stepped on, tripped over, or otherwise subjected to damage or stress.
6. Keep the battery charger clean. Contamination may cause the danger of electric shock.
7. Protect the battery charger from rain and

SAFETY INSTRUCTIONS

moisture. The penetration of water in a battery charger increases the risk of electric shock.

8. Do not operate the battery charger on easily inflammable surfaces (e.g. paper, textiles, etc.) or in combustible environments. There is danger of fire due to the heating of the battery charger during charging.
9. The temperature range over which the battery pack can be charged is typically 41 °F - 113 °F. Therefore, charging efforts outside the prescribed temperature range may automatically be blocked by the protection circuitry of the battery pack. Longest life and best performance can be obtained if the battery pack is charged in the normal room condition.
10. Disconnect charger from the power supply when not in use. This will reduce the risk of electric shock or damage to the charger if metal items should fall into the opening.
11. The charger is for indoor use only.

SPECIAL OPERATION SAFETY FOR THE BATTERY PACK

1. The Li-ion battery pack is not fully charged at the factory. Before attempting to use it ,it must be fully charged firstly.
2. The battery pack should be recharged when it fails to produce sufficient power on jobs which were easily done previously. **DO NOT CONTINUE** using product with its battery in a depleted condition.
3. Do not charge the battery in an air temperature below 41 °F or above 113 °F. This is important and will prevent serious damage to the battery. Longest life and best performance can be obtained if the battery is charged when air temperature is about 68 °F.
4. When the machine continues to be used and the battery temperature is above 113 °F, the battery can not be charged, even you put on the charger. Let the machine cool for some times and wait the temperature reduced, it can be charged again .
5. Protect the battery pack against heat, e.g. including against continuous sun irradiation and fire. There is a danger of explosion.
6. Do not carry individual battery packs in your pockets or bags, as they could short-circuit against other metal items.
7. If an exposed li-ion battery pack dose start a fire, it will burn even more violently if it comes

into contact with water or even the moisture in the air. **DO NOT** throw water on a burning li-ion battery! A fire extinguisher must be used.

8. If the battery pack becomes too hot to the touch during charging, disconnect and switch off immediately. Contact Service Centre directly.
9. Do not open the battery yourself. There is danger of a short circuit.
10. When battery pack is not in use, keep it away from other metal objects, lie paperclips, coins, keys, nails, screws or other small metal objects, that can make a connection from one terminal to another. Shorting the battery terminals together may cause burns or a fire.

MAINTENANCE AND STORAGE

1. Keep all nuts, bolts and screws tight to be sure the product is in safe working condition.
2. Check the grass collector frequently for wear or deterioration.
3. Be careful during adjustment of the product to prevent entrapment of the fingers between moving blades and fixed parts of the product.
4. Always allow the product to cool down before storing.
5. When servicing the blades, be aware that even though the power source is switched off, the blades can still be moved.
6. Replace worn or damaged parts for safety. Use only genuine replacement parts and accessories.
7. **DO NOT** attempt to open the charger and battery pack. There are no customer serviceable parts inside. Return to any authorized service center.
8. Store the appliance with battery pack fully charged at the room temperature (around 68 °F).
9. Forcing the battery to operate after it has stopped may damage the battery. For prolonged battery life, it is recommended to charge the battery at minimum once every 6 months, especially when not in use.

Service

- a) Have your tool repaired by an authorized service agent. This tool is manufactured in accordance with the relevant safety regulations. To avoid danger, equipment must only be repaired by qualified technicians.
- b) Only use parts and accessories made for this machine by the manufacturer. Failure to do

ASSEMBLY

so can result in personal injury.

RESIDUAL RISKS

Even if you are operating this product in accordance with all the safety requirements, potential risks of injury and damage remain. The following dangers can arise in connection with the structure and design of this product:

- Health defects resulting from vibration emission if the product is being used over long periods of time or not adequately managed and properly maintained.
- Injuries and damage to property due to broken application tools or the sudden impact of hidden objects during use.
- Danger of injury and property damage caused by flying objects.



Warning! This product produces an

electromagnetic field during operation! This field may under some circumstances interfere with active or passive medical implants. To reduce the risk of serious or fatal injury, we recommend persons with medical implants to consult their doctor and the medical implant manufacturer before operating this product!

ASSEMBLY

Install the handle

IMPORTANT: Unfold handle carefully to avoid pinching or damaging the control cables. Control cables must be routed above the lower handle during assembly. Please follow below steps to assemble.

1. Insert the lower handle to the two side brackets.
2. Fasten the lower handle to the device by using two arc head bolts and two fixing knobs on each side. Make sure the control cables are routed above the lower handle. (See Fig.5)
3. Insert the quick release lock bolt into the height adjust fixing blocks on the lower handle tube (1) and upper handle fixing blocks (2). Screw the bolt in and clamp it to fix the lower handle. (See Fig.6)
4. The handle height can be adjusted at three positions (L, M and H) by rotating the height adjust fixing block, make sure the arrows are aligned with same position of both height adjust fixing blocks, then you can choose the handle height level you want. (See Fig.7)
5. Push up on the cam-lock handle knobs to lock the handle in place.
6. If needed, tighten the handle nut until the cam-lock handle knob locks the handle securely.

Fitting cable clips

Attach the control cables to the handle with the clip (supplied). (See fig. 8)

Assemble grass bag and fit it onto the mower

NOTE: Switch off the tool and make sure that the blade has stopped completely. The grass bag comes partially assembled. Make sure the frame handle is outside of the bag top.

1. Slip the vinyl clip bindings over the frame. (See Fig. 9)
2. Lift the rear flap of the mower with one hand, and hook the grass bag onto the hinges. Release the rear flap. Make sure the grass bag is secured in position. (See fig. 10)

Installing the mulching plug

NOTE: Switch off the tool and make sure that the blade has stopped completely.

1. Lift the rear flap with one hand and push the mulching plug into the rear discharge tunnel until it is locked in place. Make sure that the mulching plug is locked in position. (See Fig. 11).
2. Release the rear flap, it will close back to cover the mulching plug.
3. If you want disassemble the mulching plug, hold the handle of the mulching plug, press down the hook with finger, meanwhile lift it upward slightly and pull it out.

Installing the side discharge deflector

NOTE: Switch off the tool and make sure that the blade has stopped completely.

1. Keep the mulching plug in the rear discharge tunnel.
2. Lift the side discharge door with one hand and hook in the side discharge chute with the other hand. (See Fig. 12)
3. Release the side discharge door to secure the deflector in position. (See Fig. 13)

To convert the mower



WARNING! Before changing any

accessory, switch off the tool and make sure that the blade has stopped completely!

NOTE: This lawn mower has three functions. These functions can be converted by changing accessory setting as described above. Please see the following chart for detail.

| | Mulching plug | Grass bag | Side discharge chute |
|-----------------|---------------|-----------|----------------------|
| Rear bagging * | x | √ | x |
| Mulching * | √ | x | x |
| Side discharge* | √ | x | √ |

“√”: installed “x”: uninstalled

ADJUSTMENT

* The following information:

1. Rear bagging: the grass has been cut and collected by grass bag.
2. Mulching: mulch the grass, by cutting into small pieces which then degrade and fertilize the lawn.
3. Side discharge: the grass has been cut and distributed to the side of the machine.

ADJUSTMENT



WARNING: Never operate the cutting height adjustment handle roughly. Switch off the tool and make sure that the blade has stopped completely.

Adjust the cutting height

The cutting height for all 4 wheels is adjusted by one lever.

Different cutting heights can be selected as follows:

1. Pull the adjusting handle outwards. (See Fig. 14)
2. Move it forwards or backwards to select the desired cutting height.
3. Return adjusting handle back into plate. Make sure the lever is secured in position. From position 1 to position 7, the cutting height ranges from 1.25 " to 3.75 ".

OPERATION

To insert the battery pack (See Fig. 15)

1. Open the power head door and hold it in place.
2. Align the groove on the battery pack with the corresponding ribs in the battery chamber.
3. Depress the battery pack with moderate force until it was locked in place .
4. Close the door.



WARNING: Make sure that the tool is "POWER OFF".

To remove the battery pack from the tool

1. Open the battery pack guard and hold it in place.
2. Depress the releasing/locking button. The battery pack will pop up automatically.
3. Lift and hold the battery pack while pressing the releasing/locking button again, and then remove the battery pack. (See Fig. 16)

Safety Key

The machine is fitted with a safety key, this prevents the accidental start up of cordless lawn mower.

The safety key has been design to totally disable the lawn mower when the key is removed. (See Fig. 17)

To Switch ON:

- Depress the safety lock button and keep it in place. Pull the operator presence control bar towards the handle and hold it in position. The motor will start to work, blade will rotate. Then release the safety lock button. (See Fig. 18)

CAUTION!

1. Do not start the motor in high grass! Start the mower blade before pushing the mower into grass.
2. Before starting the lawn mower, ensure that the battery pack and safety key are correctly installed in place.
3. Before operating the device, remove stones, loose pieces of wood and other objects from the cutting area.

To Switch OFF:

1. Release the operator presence control bar.



WARNING:

The blade will rotate on for several seconds after the tool has been switched off.

Use self-propel function with the blade cutting (See Fig. 19)

1. Start the mower follow the steps above.
2. While holding the operator presence control bar with one hand, then push the self-propel control bar to the handle and the machine will drive forward.
3. To stop the moving lawn mower, just release the self-propel control bar.

Operate the lawn mower

Operation on a slope.

NOTE: Slopes are a major factor related to slip and-fall accidents, which can result in severe injury.



WARNING: Always be sure of your footing on slopes. Operation on slopes requires extra caution. If you feel uneasy on a slope, do not mow it.

ADJUSTMENT

DO:

- Mow across the face of slopes; never mow up and down. Exercise extreme caution when changing direction on slopes.
- Watch for holes, ruts, rocks, hidden objects, or bumps which can cause you to slip or trip. Tall grass can hide obstacles.

DO NOT:

- Do not mow near drop-offs, ditches or embankments; you could lose your footing or balance.
- Do not mow slopes greater than 15 degrees.
- Do not mow on wet grass. Unstable footing could cause slipping.

Mower overload protection

To prevent overload conditions, do not try to cut too much grass at one time. Slow down your cutting pace or raise the cut height. Your mower has built-in overload circuit protection. When the mower is overloaded, the motor will shut down.

Check to see if grass has collected beneath the deck and clean it if necessary, then restart the mower.

Battery high temperature protection

The battery pack will generate heat during operation. The heat dissipates more slowly in hot weather. If the battery temperature exceeds more than 113 °F during operation, the protection circuit will immediately shut down the mower to protect the battery pack to avoid any damages. Release the control bars, wait until the battery pack cools down, then restart the mower.

Emptying the grass bag

NOTE: Before taking off the grass bag, switch OFF the power and wait until the blade has come to a stop.

1. To take off the grass bag, use one hand to lift up rear flap and the other hand to grab onto the carry handle. The rear flap automatically falls down after the bag is removed.
2. Empty the grass debris in the grass bag, and attach grass bag back to the mower.

NOTE: If any grass residue is caught in the discharge chute, clean it using a brush. Do not remove grass debris in the mower chassis or

on the blade by hand or your feet. Instead use suitable tools such as a brush or broom. To ensure that the cut grass can be collected into grass bag, the discharge opening and inside the mower chassis must be cleaned of any blockage.

Charging the battery pack

NOTE: Remove the battery pack from the charger after it has been fully charged.

NOTE: Battery should be fully charged before first use.

NOTE: Make sure the mains voltage is the same as rating label which is located on the charger. Connect the charger to a power supply. The red LED will light up.

1. To insert the battery pack into the charger, align the raised ribs of the battery pack with the grooves of the charger then push it in. (See Fig. 20)
2. The green LED light of the charger will flash during normal charging.
3. After charging is complete, the LED will light solid green.

Power indicator (Fig. 21)

This Li-Ion battery pack is equipped with a power indicator which is used to show the battery pack's remaining charge. Press the power indicator button to check battery charge as below. The LEDs will stay lit for approximately 4 seconds.

To obtain the best life from the battery

1. Never allow the battery to completely discharge before recharging. The battery pack should be placed on the charger whenever the battery pack is noticeably running down or the tool no longer performs a task it previously performed.
2. Avoid conducting short charges. Make sure that the battery is fully charged each time by allowing the charger to complete its full charging cycle.
3. Avoid allowing loose items like screws or nails etc. to be stored with battery packs as these or similar items can short battery packs and cause a fire or explosion.
4. Always unplug the charger when not in use and store in a dry and secure place.
5. Avoid charging or storing your battery in temperatures below 41°F(5°C) and above 113°F(45°C).
6. After use, allow the battery to pack to cool down for approximately 30 minutes before

MAINTENANCE AND STORAGE

attempting to recharge.

MAINTENANCE AND STORAGE



WARNING !

Before performing any maintenance or cleaning work, always ensure that the battery pack/safety key has been removed and wait until the blade has stopped completely and the tool has cooled down.

Cleaning

Cleaning the product

- Use a soft brush to remove any accumulated dust and debris. Wear safety glasses to protect your eyes whilst cleaning.
- Wipe down the product enclosure with a slightly damp cloth. Do not spray the unit with water. Ingress of water may destroy the switch unit and the electric motor.

Maintenance

NOTE: Always wear gloves when handling or working near the sharp blades.

- 1) Keep all nuts, bolts and screws tight to be sure that the machine is in safe working condition.
- 2) Check the grass bag frequently for wear or deterioration.
- 3) Examine the machine and replace worn or damaged parts for safety.

Removing/Installing the blade (See Fig. 22 & Fig. 23)

1. Using a wrench locate on the blade bolt nut.
2. Wearing heavy gloves hold the blade fixed and turn the wrench anti-clockwise and remove the bolt.
3. Fitting the replacement blade correctly with marking facing up and align pegs correctly then fit the bolt and retighten the bolt securely to torque 15- 23 ft. lb.



WARNING !

Replace or re-sharpen the mowing blade at the end of the mowing season. Always have the mowing blade re-sharpened or replaced by a customer service center (measurement of imbalance).

Unbalanced blades will cause the lawn

mower to vibrate violently-risk of accident!

Battery Maintenance:

Use the following procedures to enable optimum usage of the battery:

1. Protect the battery against moisture and water.
2. Store the battery only with in a temperature range from 31 °F to 113 °F. As an example, do not leave the battery in the lawn mower in direct sunlight.
3. Clean the battery occasionally with a soft, clean and dry brush.
4. If you do not use the product for a long time, please discharge and recharge the battery pack once every 6 months.

Storage and transport

After cleaning the unit thoroughly, store it in a dry room and allow the motor to cool down.

1. Release the Handle Quick release levers, and fold the handles down.
2. Position the lower handle lock pin into the mower bracket. Lock the handles in place by closing the quick release handle.

NOTE:

Remove the safety key and battery packs. Ensure cables are not trapped when folding/unfolding the handle.

Transport

Use the original packaging to ship whenever possible. Remove the battery before transportation.

VERTICAL STORAGE FEATURE INSTRUCTION

1. Ensure that the cutting height setting is at or below position 3. If it is not, lower it. ①



2. Disengage the cam-lock handle knob to "unlocked" position ② and fold down handle and lock handle in the horizontal position ③.

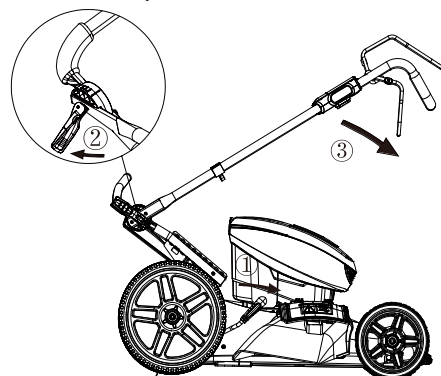

TROUBLE SHOOTING

TROUBLE SHOOTING

WARNING !

Before performing any repair work, always ensure that the battery pack/safety key has been removed and wait until the blade has stopped completely and the tool has cooled down .

WARNING !

Always wear heavy duty gloves when adjusting or cleaning ,especially when handling sharp objects.

| Fault/malfunction | Cause | Remedy |
|--------------------------------------|--|--|
| Mower fails to start | Safety key is not inserted | Insert safety key |
| | Battery is not correctly inserted | Remove the battery and reinsert |
| | Mower standing in high grass | Start motor on shorter grass or already mowed area ;change cutting height if necessary |
| | The mower housing is clogged | Clean housing so that the blade can move freely |
| | Battery has no power | Check and recharge battery |
| Mower stops working / loses power | Cutting height is improper | Adjust the cutting height |
| | Discharge chute/ housing is blocked | Clean the discharge chute/ housing |
| | Cutting blade is worn or damaged | Replace with new blade from dealer service centre |
| | Battery performance decreasing | Check the battery performance and charge it if necessary |
| | Mower Overloaded | Wait until reset occurs, or remove and reinsert battery to reset |
| Grass bag is not filled sufficiently | Cutting height is too Low | Adjust and increase cutting height |
| | The lawn / grass is wet | Allow the lawn to dry |
| | Discharge tunnel/ housing is blocked | Clean the discharge tunnel/ housing |
| | Underside of the mower deck is clogged. | Clean the underside of the mower deck |
| | Cutting blade is worn or damaged. | Replace blade |
| Mower vibrating at higher speed | Cutting blade is unbalanced | Replace the blade |
| | Blade is Loosened /incorrectly fitted | Tighten the blade bolt |
| Mower does not mulch properly | Cutting height set to low Deck has wet grass on underside of deck | Adjust cutting height Clean underside of deck and wait until grass is dry |
| Mower cuts unevenly | The blade is damaged Blade is assembled incorrectly | Sharpen the blade or replace Re-assemble blade correctly |

WARRANTY

WARRANTY

Product Warranty

Please keep your original purchase receipt in a safe place as proof of purchase. Warranty coverage for this product must be verified by the original purchase receipt. The warranty period begins on the day that the product was purchased from an authorized retailer of Yard Force products.

Warranty coverage only applies to the original purchaser and is not transferrable.

Warranty coverage is only provided on products purchased from authorized Yard Force retailers.

Warranty only applies to products purchased and OPERATED in the USA or Puerto Rico. Any product purchased or operated outside of the USA or Puerto Rico is not covered by any warranty.

(5) Five-Year Warranty on Yard Force YF40vRX21-SP Lawn Mower and

(3) Three Year Warranty on YF40vRX Battery Pack and Charger

The Yard Force YF40vRX mower has a 5-Year Limited Warranty and YF40vRX Battery Pack and Charger has a 3-Year Limited Warranty from the date of purchase against manufacturer defects for residential use only. Commercial use voids the warranty. This warranty does not cover accidental damage, unreasonable use, normal wear and tear, neglect or non-compliance with the operating, safety and maintenance instructions. All service, outside of normal maintenance as described in this manual, must be done by an authorized service technician. Any unauthorized service or changes to the original configuration of this product will void the warranty. All parts and accessories used on and with this product must be manufactured and/or authorized by Merotec Inc.

(90) Ninety-Day Warranty - Accessories

The accessories included with the mower including the blade and other similar parts are warranted against manufacturer defects for residential use only for a period of 90 days from the date of purchase.

Warranty does not cover loss of use or other consequential damages arising from any of the above, nor does it cover repairs made or attempted by unauthorized persons.

This warranty is void if the product is used for commercial, rental or industrial purposes.

Certain parts, attachments and accessories are subject to normal wear and tear and are excluded from the warranty.

Service and Warranty Claims Process

Contact the Yard Force Support Center toll-free at **(866) 902-9690 Monday-Friday between 8:30 AM and 5:00 PM** Eastern Time for service and warranty support.

Yard Force Service Support agents can help you troubleshoot problems over the phone to get you back up and running as quickly as possible. In the situation where service or warranty inspection is needed, please follow these steps:

1. Call Yard Force at **(866) 902-9690 Monday-Friday between 8:30 AM and 5:00 PM Eastern Time.**
2. Send in proof-of-purchase and serial number (if applicable) to confirm warranty Coverage as directed by Yard Force.
3. If service or a warranty evaluation is requested, Yard Force will provide an RGA number that should be used in all communications with Yard Force and is required to be indicated on the product itself and on the outside of the box.
4. All shipments to Yard Force must have an RGA number. Any shipment received that does not have an RGA number clearly marked on the outside of the box will be refused.
5. All shipments must be sent pre-paid, Yard Force does not pay for any shipping costs for service or warranty evaluation. Yard Force is not responsible for any packages that are lost by carrier. We recommend that shipments are made by a carrier that provides tracking and delcert confirmation

For more information or to ask questions, please call toll-free **(866) 902-9690 Monday-Friday between 8:30 AM and 5:00 PM Eastern Time.**

SAVE THESE INSTRUCTIONS



Need Help?

Please do not return the product to your place of purchase yet. We're here to help and take care of all your needs.

Contact our customer service department for help with:

- Product assembly or use
- Missing or damaged parts
- Troubleshooting
- Replacement parts and accessories

You can submit a support request by scanning the QR code on this page, or by visiting:
www.YardForceUSA.com/contact-support

Scan Code to connect with Yard Force Support



1-866-902-9690



www.YardForceUSA.com

Register your product today to maintain warranty coverage and stay up to date with information on the use, care, maintenance and service of your product.

Register online today at:

www.yardforceusa.com/product-registration



Merotec Inc.
3655 Kennesaw North Industrial Parkway
Kennesaw, GA 30144
Copyright © 2023 Merotec Inc.

Made in China at a SUMEC manufacturing facility.

Part Number: YF40VRX21-SPMAN-A
2301

MAINTENANCE AND STORAGE

attempting to recharge.

MAINTENANCE AND STORAGE

WARNING !

Before performing any maintenance or cleaning work, always ensure that the battery pack/safety key has been removed and wait until the blade has stopped completely and the tool has cooled down.

Cleaning

Cleaning the product

- Use a soft brush to remove any accumulated dust and debris. Wear safety glasses to protect your eyes whilst cleaning.
- Wipe down the product enclosure with a slightly damp cloth. Do not spray the unit with water. Ingress of water may destroy the switch unit and the electric motor.

Maintenance

NOTE: Always wear gloves when handling or working near the sharp blades.

- 1) Keep all nuts, bolts and screws tight to be sure that the machine is in safe working condition.
- 2) Check the grass bag frequently for wear or deterioration.
- 3) Examine the machine and replace worn or damaged parts for safety.

Removing/Installing the blade (See Fig. 22 & Fig. 23)

1. Using a wrench locate on the blade bolt nut.
2. Wearing heavy gloves hold the blade fixed and turn the wrench anti-clockwise and remove the bolt.
3. Fitting the replacement blade correctly with marking facing up and align pegs correctly then fit the bolt and retighten the bolt securely to torque 15- 23 ft. lb.

WARNING !

Replace or re-sharpen the mowing blade at the end of the mowing season. Always have the mowing blade re-sharpened or replaced by a customer service center (measurement of imbalance).

Unbalanced blades will cause the lawn

mower to vibrate violently-risk of accident!

Battery Maintenance:

Use the following procedures to enable optimum usage of the battery:

1. Protect the battery against moisture and water.
2. Store the battery only with in a temperature range from 31 °F to 113 °F. As an example, do not leave the battery in the lawn mower in direct sunlight.
3. Clean the battery occasionally with a soft, clean and dry brush.
4. If you do not use the product for a long time, please discharge and recharge the battery pack once every 6 months.

Storage and transport

After cleaning the unit thoroughly, store it in a dry room and allow the motor to cool down.

1. Release the Handle Quick release levers, and fold the handles down.
2. Position the lower handle lock pin into the mower bracket. Lock the handles in place by closing the quick release handle.

NOTE:

Remove the safety key and battery packs. Ensure cables are not trapped when folding/unfolding the handle.

Transport

Use the original packaging to ship whenever possible. Remove the battery before transportation.

VERTICAL STORAGE FEATURE INSTRUCTION

1. Ensure that the cutting height setting is at or below position 3. If it is not, lower it. ①

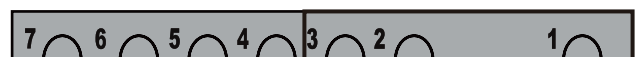

2. Disengage the cam-lock handle knob to "unlocked" position ② and fold down handle and lock handle in the horizontal position ③.

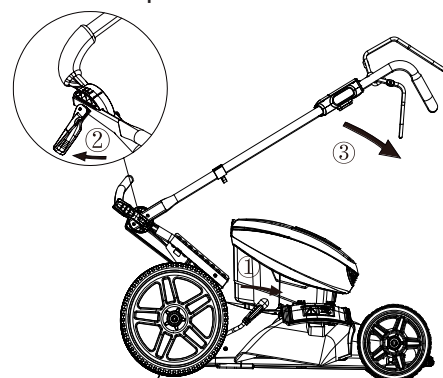

MAINTENANCE AND STORAGE

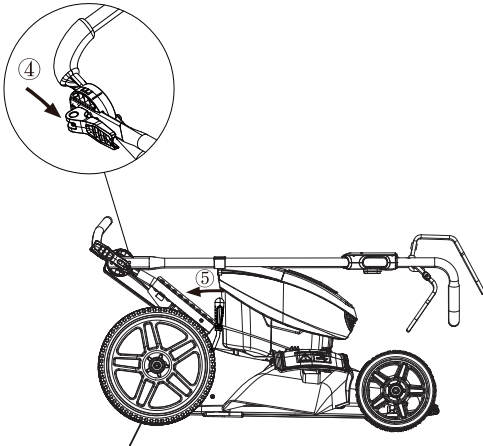

4. Lock the cam-lock handle knob for vertical storage ④, then adjust the cutting-height setting to position 4 or above ⑤.



5. Tilt up and store. Make sure to position the mower so that the blade is facing a wall.

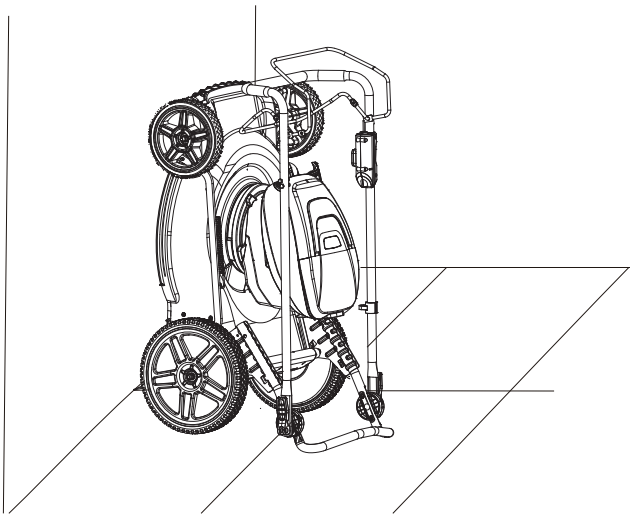

WARNING!

1. Do not store the mower in a position that is beyond the vertical (90°) position;
2. Do not transport the mower in the vertical-stow position.
3. Do not attempt to start the mower in the vertical-stow position.